

The logo for GUARDI, featuring a stylized white arch of vertical bars above the word "GUARDI" in a bold, white, sans-serif font, all set against a green rectangular background.

GUARDI



GERÄTEHAUS M

GARDEN SHED M

Montageanleitung
assembly instruction

www.guardi.at | www.guardi.de



Zeitaufwand: ca. 6 Stunden
Time required: approx. 6 hours



2 Personen
2 persons

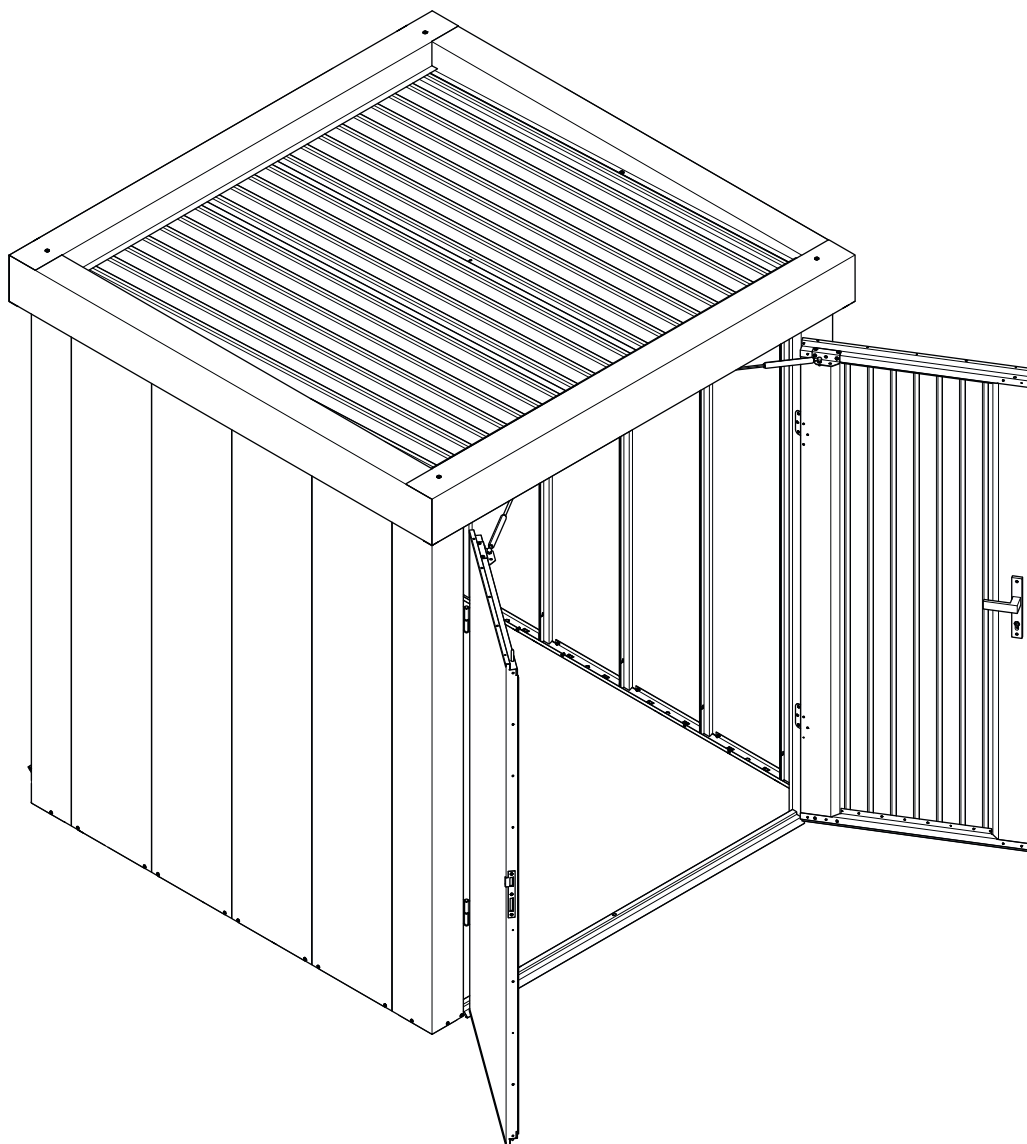

Allgemeine Informationen / General information	4/7
Werkzeug / Tools	10
Lieferumfang / Scope of supply	12
Material / Materials	13
Montage mit Bodenrahmen / Assembly with floor frame	15
Montage ohne Bodenrahmen / Assembly without floor frame	16
Zufriedenheit und Kontakt / Feedback and contact	36

Montageanleitung lesen und aufbewahren

Diese Montageanleitung enthält wichtige Informationen zur Sicherheit und Montage der Gerätehaus.

Lesen Sie die Montageanleitung, insbesondere die Sicherheitshinweise, sorgfältig durch, bevor Sie das Gerätehaus aufbauen und verwenden.

Die Nichtbeachtung dieser Montageanleitung kann zu Verletzungen oder zu Schäden an dem Gerätehaus führen. Die Montageanleitung basiert auf den in der Europäischen Union gültigen Normen und Regeln. Bewahren Sie die Montageanleitung für die weitere Nutzung auf. Wenn Sie das Gerätehaus an Dritte weitergeben, geben Sie diese Montageanleitung mit.

Technische Daten

Modell:	GUARDI Gerätehaus
Größe:	Medium
Produktmaße (BxTxH):	1900 x 1900 x 2130 mm
Innenmaße (BxT):	1716 x 1716 mm
Türlichte Breite:	1487 mm
Stauraumvolumen:	5,89 m ³

Vorsicht

Verletzungsgefahr
Scharfkantige oder spitze Bauteile können zu Handverletzungen führen.
Verwenden Sie bei der Montage Arbeitshandschuhe.

Hinweise

Für eine sichere Montage sind 2 Personen erforderlich.
Um Kratzer an dem Gerätehaus zu vermeiden, verwenden Sie die Kartonverpackung als Unterlage.
Öffnen Sie die Kartonverpackung nicht mit einem scharfen Gegenstand wie Messer o.ä.
Für eine sichere Montage das Gerätehaus nicht bei Wind aufstellen.
Platzbedarf: Basis des Gerätehaus plus mind. 30 cm auf jeder Seite.

Symbole in der Anleitung



Arbeitsschritt mithilfe einer zweiten Person ausführen.



Gezeigten Bauteil beim Einbau mithilfe einer Wasserwaage ausrichten.



Schutzfolie der Bleche abziehen.



Schraube/Mutter vorerst nur handfest anziehen.



Schraube/Mutter fest nachziehen.



Weitere Informationen auf der angeführten Seite der Montageanleitung.

Montage

1. Lieferumfang auf Vollständigkeit und Beschädigung prüfen.
2. Schutzfolie der Bleche erst bei den entsprechenden Arbeitsschritten abziehen.
3. Schrauben pro Arbeitsschritt locker fixieren.
4. Bleche positionieren.
5. Schrauben mit Schraubendreher fest anziehen.
6. Für eine Bodenverankerung sorgen, damit das Gerätehaus sturmsicher ist.

Bodenbefestigung

Hinweis

Um bei starkem Wind Schäden an das Gerätehaus zu vermeiden ist das Gerätehaus am Boden zu befestigen.

Die Art der Bodenbefestigung variiert je nach Untergrund. Das Befestigungsmaterial ist nicht im Lieferumfang enthalten.

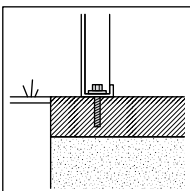
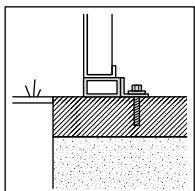

Betonfundament

Befestigung mit und ohne Rahmen möglich.
Verwendung von 10 mm Schrauben und 12 mm Dübel.
Je nach Hüttengröße 15 bis 22 Stück.

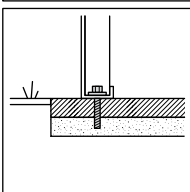
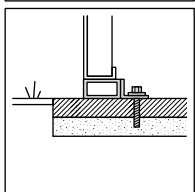

Betonplatten

Befestigung mit und ohne Rahmen möglich.
Verwendung von 10 mm Schrauben und 12 mm Dübel.
Je nach Hüttengröße 15 bis 22 Stück.
Empfohle Betonplattengröße: min. 5 x 50 x 50 cm

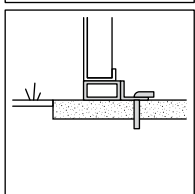

Erdboden

Zur Befestigung wird der Rahmen benötigt.
Verwendung der Anker aus dem Rahmen-Set.

Bodenfeuchtigkeit

Beim Aufbau auf einer Wiese oder auf Schotter eine Dampfsperre bzw. Kondensatfolie unterlegen, um zu verhindern, dass Bodenfeuchtigkeit in das Gerätehaus aufsteigt.

Regensammelsystem

Alternativ zu den mitgelieferten Fallrohren kann ein eigenes Regensammelsystem mit G1/2" Anschluss montiert werden.

Türen einrichten

Falls die beiden Türflügel nicht fluchten, die obere Blende entfernen und das Gerätehaus korrekt ausrichten. Die Blende wieder ordnungsgemäß einsetzen, um eine Deformierung zu vermeiden.

Pflege

- Keine aggressiven Chemikalien wie z.B. Chlor oder Streusalz lagern.
- Keine scheuernden Reinigungsmittel verwenden.
- Verschmutzungen mit Wasser und Seife entfernen.

Jährliche Wartung

- Türschloss des Gerätehaus mit geeignetem Schmierstoff ölen.
- Tür-Scharniere ölen.
- Dachrinne reinigen und von Schmutz, Moos und Flechten befreien. Dazu das hintere Blech entfernen.

Einsatz

Aus Sicherheitsgründen Tür des Gerätehaus immer verriegeln.
Berücksichtigen, dass sich im Sommer hohe Temperaturen in dem Gerätehaus entwickeln können.

Schneeräumung

Vorsicht

Verletzungsgefahr

Das Dach zur Schneeräumung nicht betreten. Benutzen Sie Leiter und Besen.

Bei Schneefall das Dach regelmäßig vom Schnee befreien, um mögliche Schäden oder Instabilitäten zu vermeiden.

Für eine sichere Schneeräumung geeignete Ausrüstung benützen und die örtlichen Sicherheitsvorschriften beachten.

Read and keep the assembly instructions

These assembly instructions contain important information about the safety and assembly of the garden shed.

Read the assembly instructions carefully, especially the safety information, before assembling and using the garden shed.

Failure to follow these assembly instructions may result in injury or damage to the garden shed. The assembly instructions are based on the standards and rules applicable in the European Union. Keep the assembly instructions for further use. If you pass the garden shed on to a third party, please include these assembly instructions.

Technical data

Modell	GUARDI garden shed
Size:	Medium
Dimensions (WxDxH):	1900 x 1900 x 2130 mm
Internal dimensions (WxD):	1716 x 1716 mm
Door clearance width:	1487 mm
Storage room volume:	5,89 m ³

Caution

Risk of injury
Sharp-edged or pointed components can cause hand injuries.
Use work gloves during assembly.

Notice

2 people are required for safe assembly.
To avoid scratching the waste container, use the cardboard packaging as a base.
Do not open the cardboard packaging with sharp objects such as knives.
Do not set up the garden shed in windy conditions to ensure safe assembly.
Space requirements: Base of the garden shed plus at least 30 cm on each side.

Symbols in the instructions



Carry out this working step with assistance from another person.



Align the component shown using a spirit level during installation.



Pull protective film off the sheets.



Initially, only tighten the screw/nut hand-tight.



Tighten the screw/nut firmly.



You can find more information on the listed page of the assembly instructions.

Assembly instructions

1. Check the scope of delivery for completeness.
2. Pull protective film off the sheets during the corresponding work steps.
3. Loosely fix the screws for each work step.
4. Position the plates.
5. Tighten the screws firmly with the screwdriver.
6. Ensure that floor anchoring is used to prevent the garden shed blowing away in windy weather.

Floor anchoring

Notice

To prevent damage to the garden shed in high winds, it must be anchored in the ground.

The ideal method of anchoring the product in the ground varies depending on the subsurface. Anchoring material is not included in the scope of delivery.

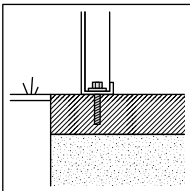
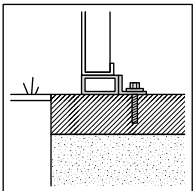

Concrete foundations

Fastening possible with and without frame.
Use 10 mm screws and 12 mm anchor plugs.
15 – 22 pieces depending on shed size.

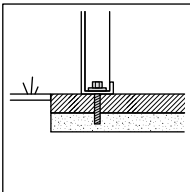
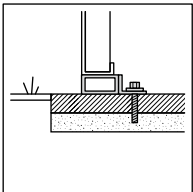

Concrete slabs

Fastening possible with and without frame.
Use 10 mm screws and 12 mm anchor plugs.
15 – 22 pieces depending on shed size.
Recommended slab size: min. 5 x 50 x 50 cm

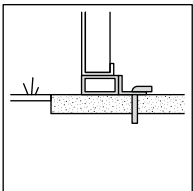

Ground

The frame is required for fastening.
Use the anchor from the frame set.

Ground moisture

When assembling on a lawn or gravel, lay down a moisture barrier or condensation film to prevent ground moisture from getting into the garden shed.

Rain collection system

A rain collection system with G1/2" connection can be assembled as an alternative to the supplied drain pipes.

Setting up doors

If the two door leaves are not aligned, remove the upper panel and correctly align the garden shed. Reinsert the panel properly to prevent deformation.

Care

- Do not store aggressive substances such as chlorine or road salt.
- Do not use abrasive cleaning agents.
- Remove stains with water and soap.

Annual maintenance

- Oil the garden shed lock with a suitable lubricant.
- Oil the door hinges.
- Clean the roof gutters and remove dirt, moss and lichen. Remove the rear panel to do so.

Use

For reasons of safety, always lock the door of the garden shed. Please take into consideration that high temperatures may develop inside the garden shed during the summer months.

Snow clearance

Caution

Risk of injury

Do not walk on the roof to remove snow. Use ladders and brooms.

In case of snowfall, clear the roof regularly of snow in order to avoid possible damage or instability.

Use suitable equipment and observe the local safety regulations for safe snow clearance.

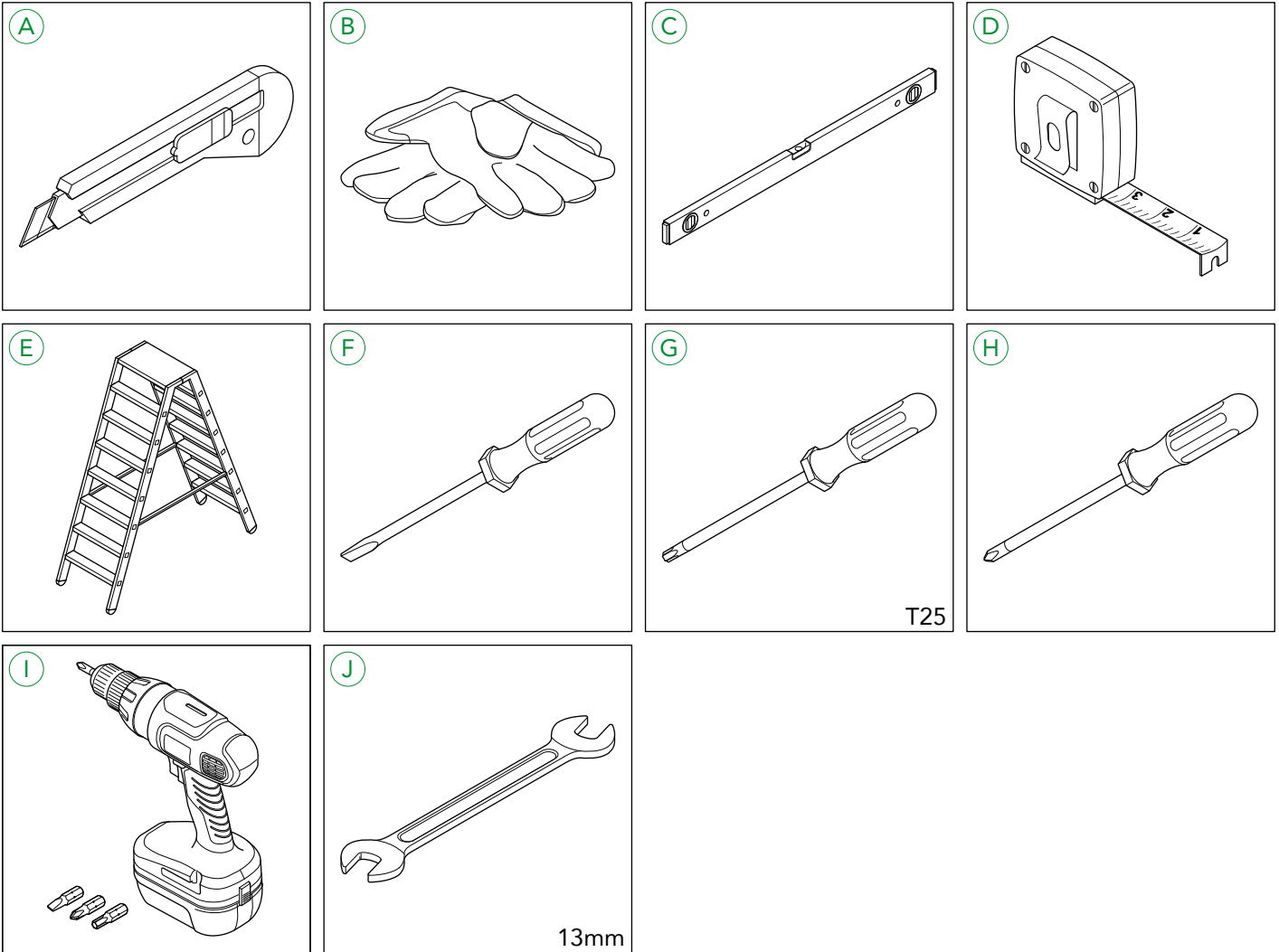

Werkzeug / Tools

- A Messer / Utility knife
- B Arbeitshandschuhe / Work gloves
- C Wasserwaage / Spirit level
- D Maßband / Measuring tape
- E Leiter / Ladder
- F Schraubendreher (Schlitz) / Slot screwdriver
- G Schraubendreher (Torx) / Torx screwdriver
- H Schraubendreher (Kreuz) / Crosshead screwdriver
- I Akkuschauber (optional) / Electric drill (optional)
- J Schraubenschlüssel / Wrench

Hinweise

Für eine zeitsparende Montage einen Akkuschauber auf schwacher Drehmomentstufe verwenden. Festigkeit mit dem mitgelieferten Schlüssel manuell kontrollieren. Das Dach während der Montage nicht betreten und bei Bedarf eine Leiter benutzen.

Notices

For faster assembly, use an electric screwdriver set to a low speed.
Manually check the strength with the supplied wrench.
Do not climb onto the roof during assembly, use a ladder if needed.

LIEFERUMFANG

SCOPE OF SUPPLY

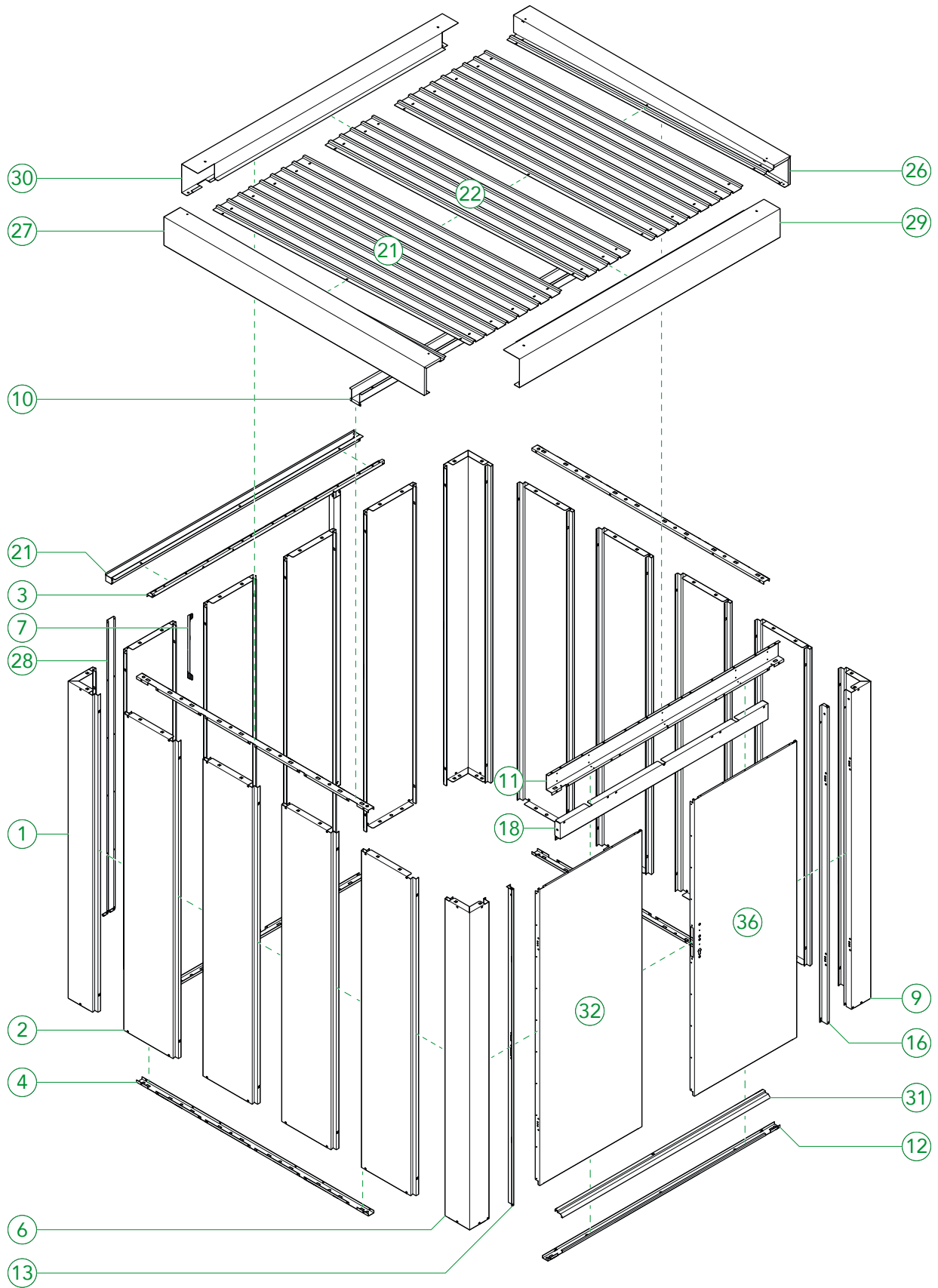

<p>① 2x</p>	<p>② 12x</p>	<p>③</p>	<p>④ 5x</p>
<p>⑤</p>	<p>⑥</p>	<p>⑦</p>	<p>⑧ 110x</p> <p>M5x10</p>
<p>⑨</p>	<p>⑩</p>	<p>⑪</p>	<p>⑫</p>
<p>⑬</p>	<p>⑭ 2x</p>	<p>⑮ 29x</p> <p>M5x15</p>	<p>⑯</p>
<p>⑰ 2x</p>	<p>⑱</p>	<p>⑲ 8x</p>	<p>⑳ 2x</p>

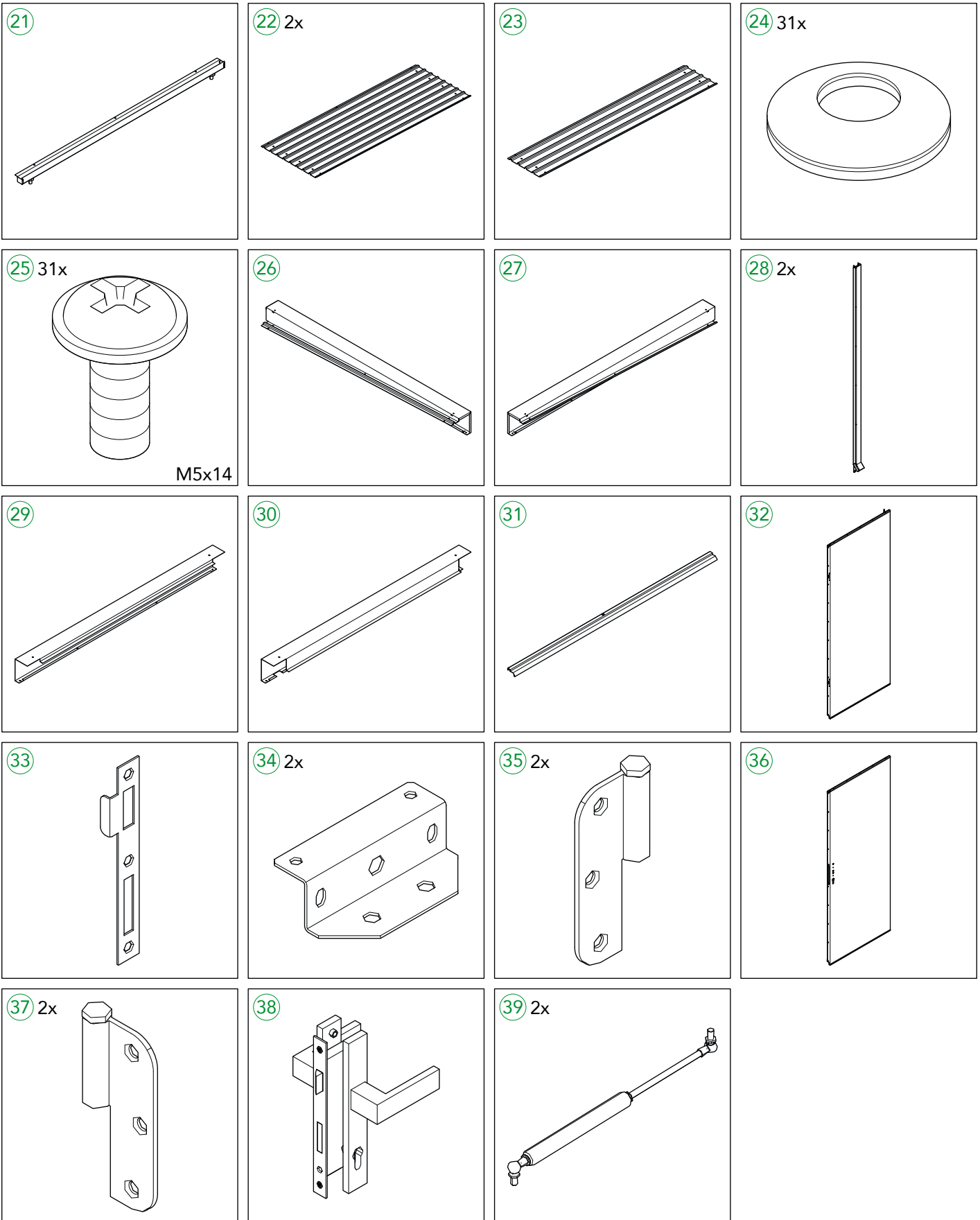

BODENRAHMEN (OPTIONAL)

FLOOR FRAME (OPTIONAL)

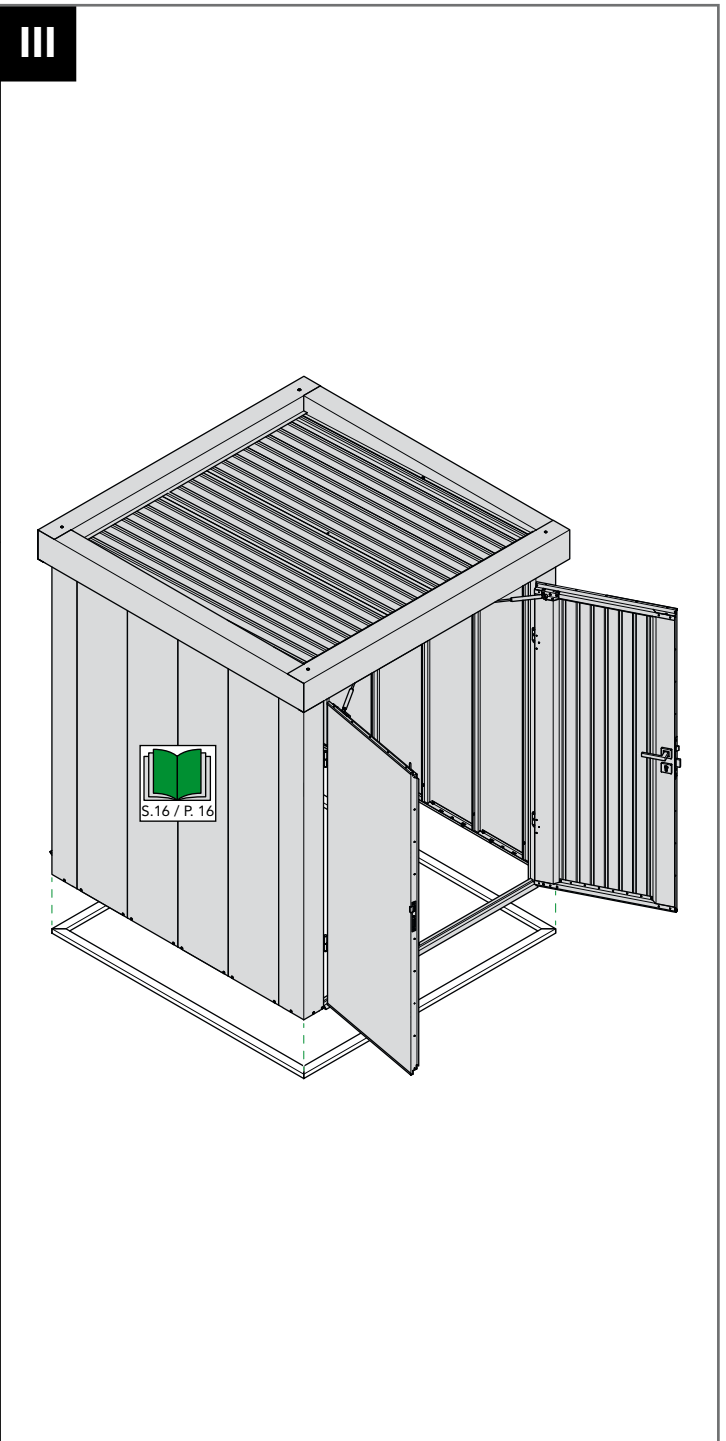
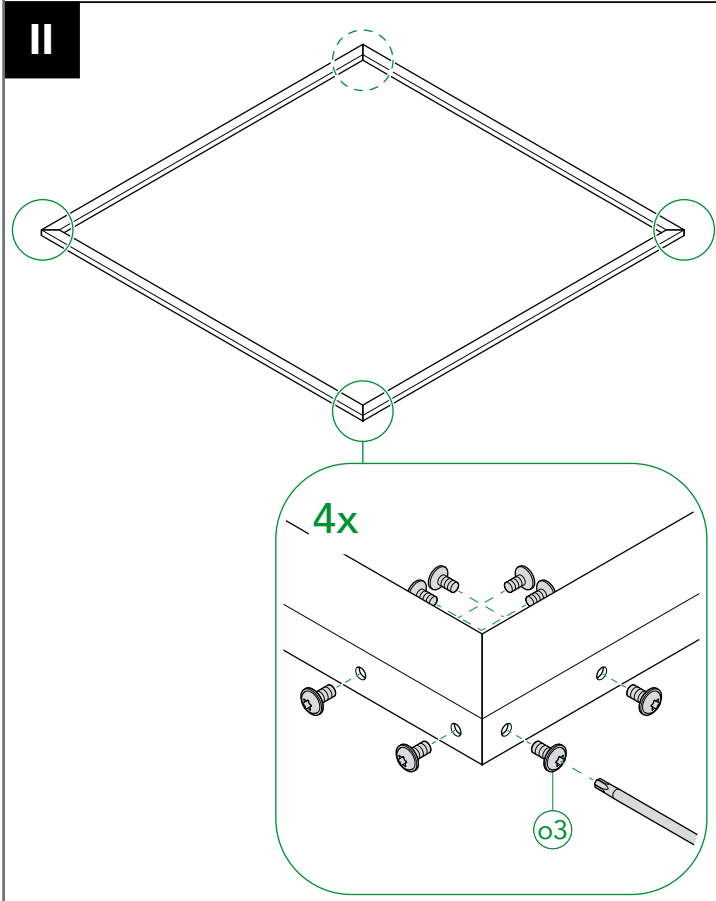
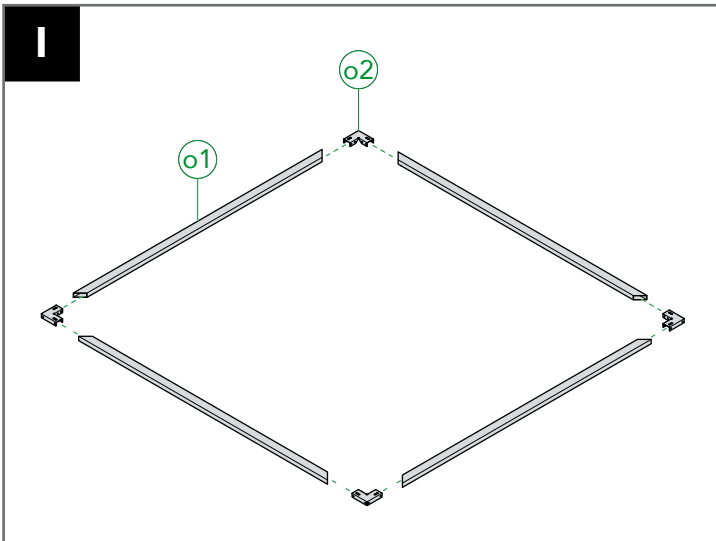
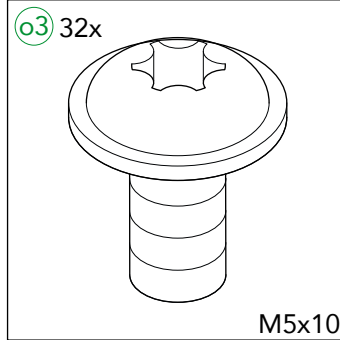
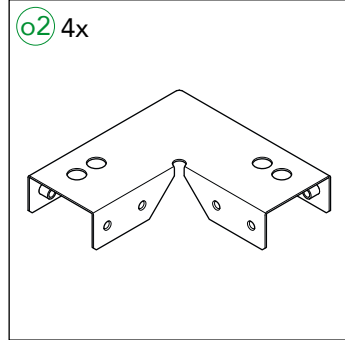
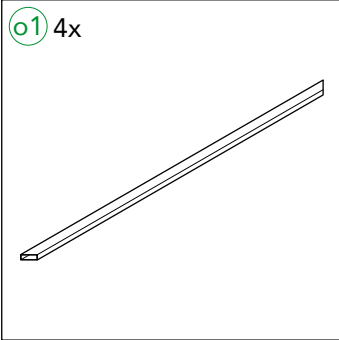

01

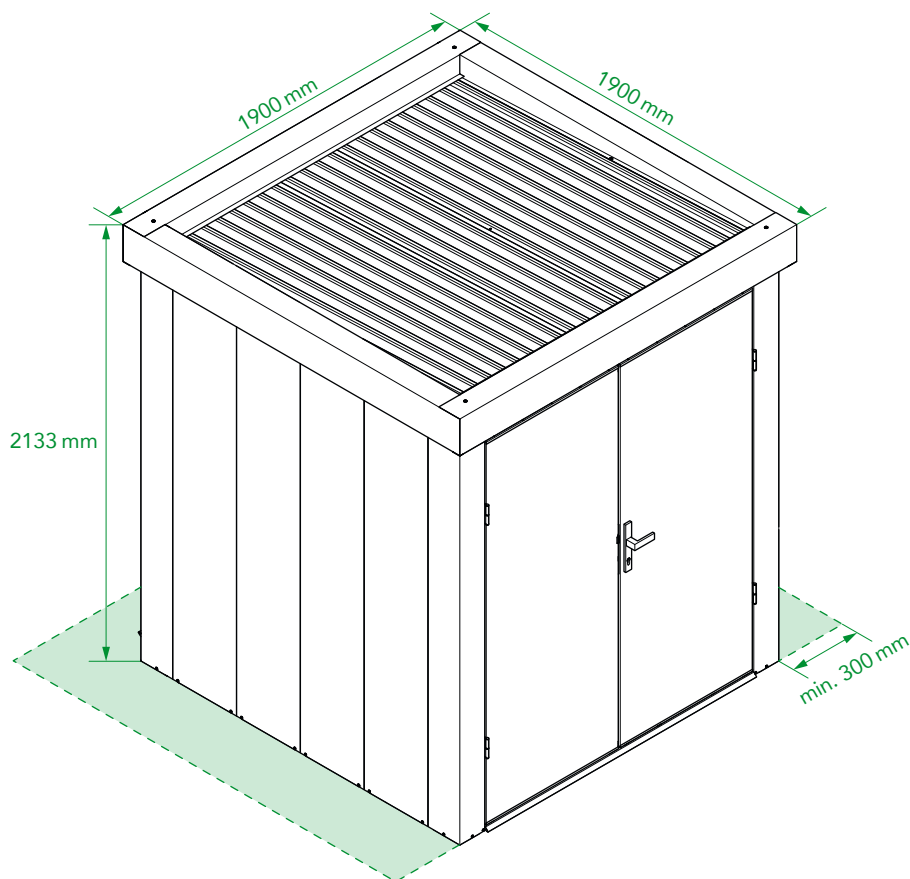

02

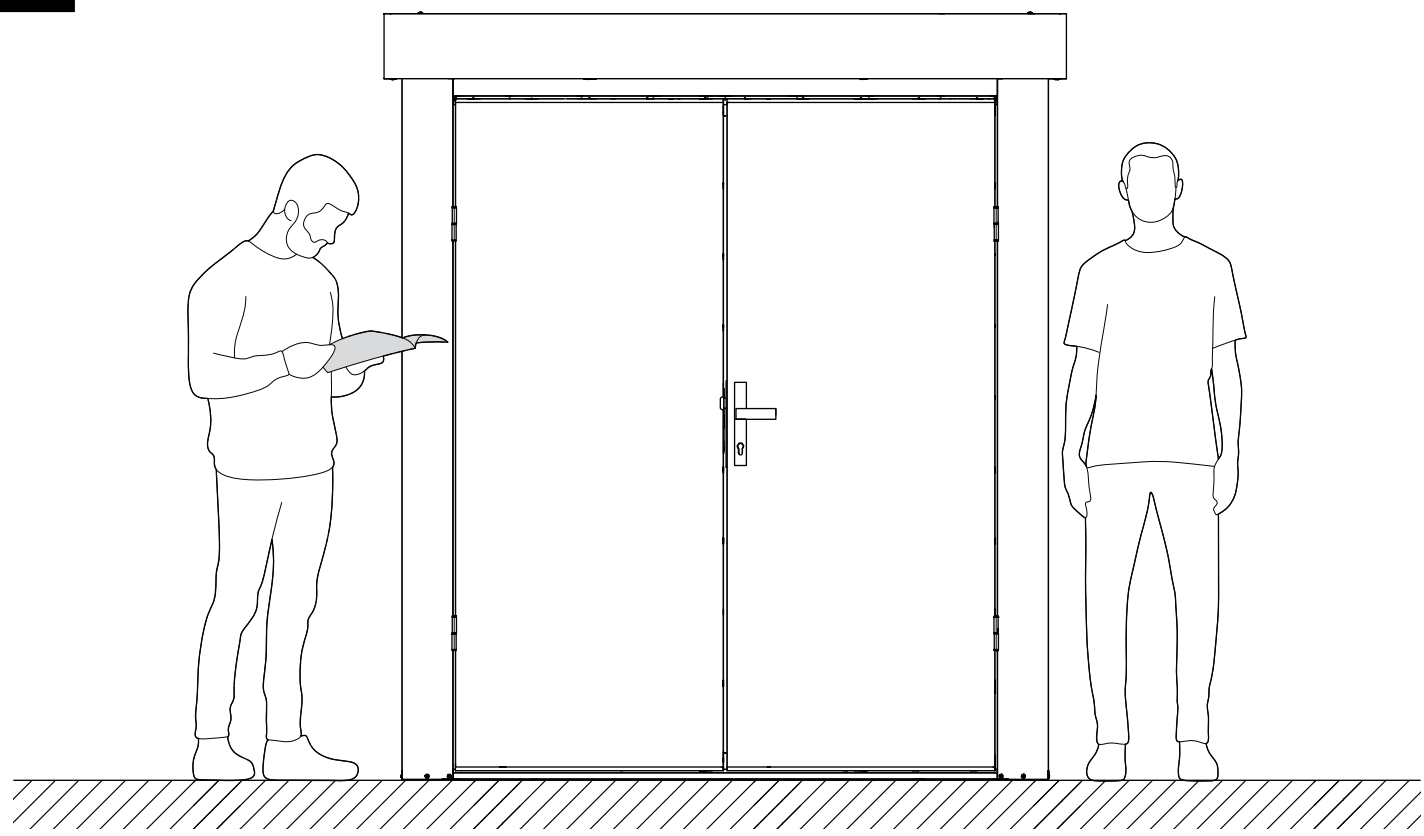

03

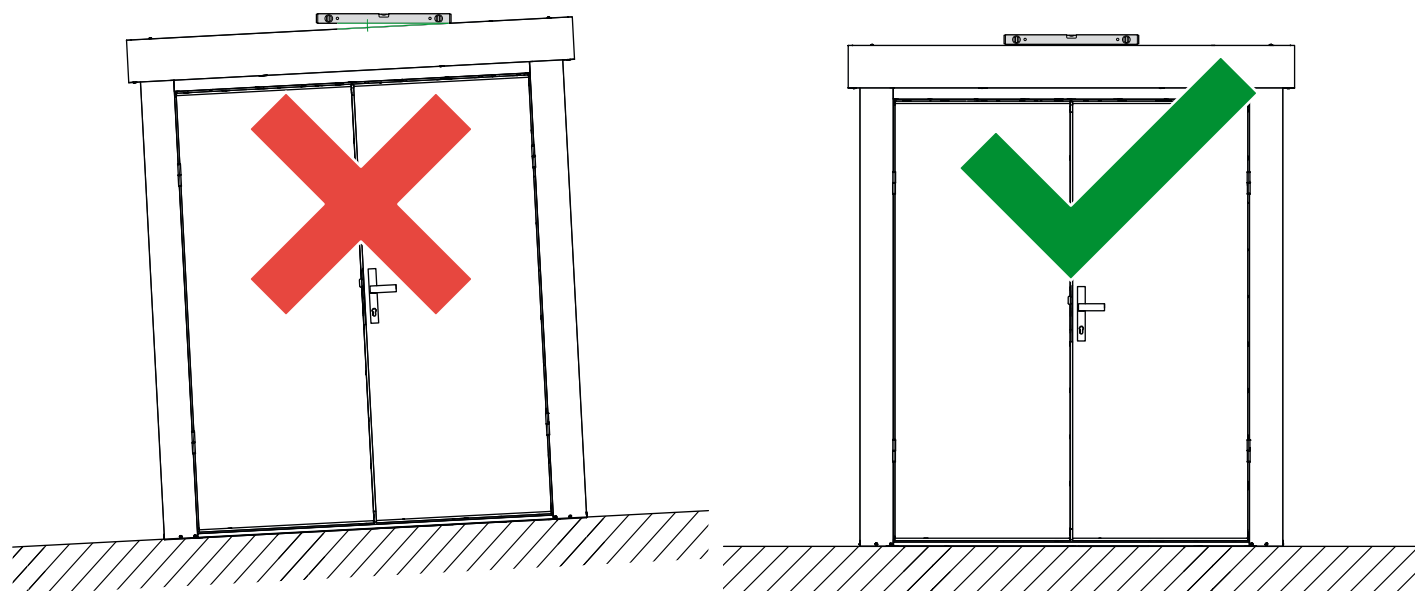

04

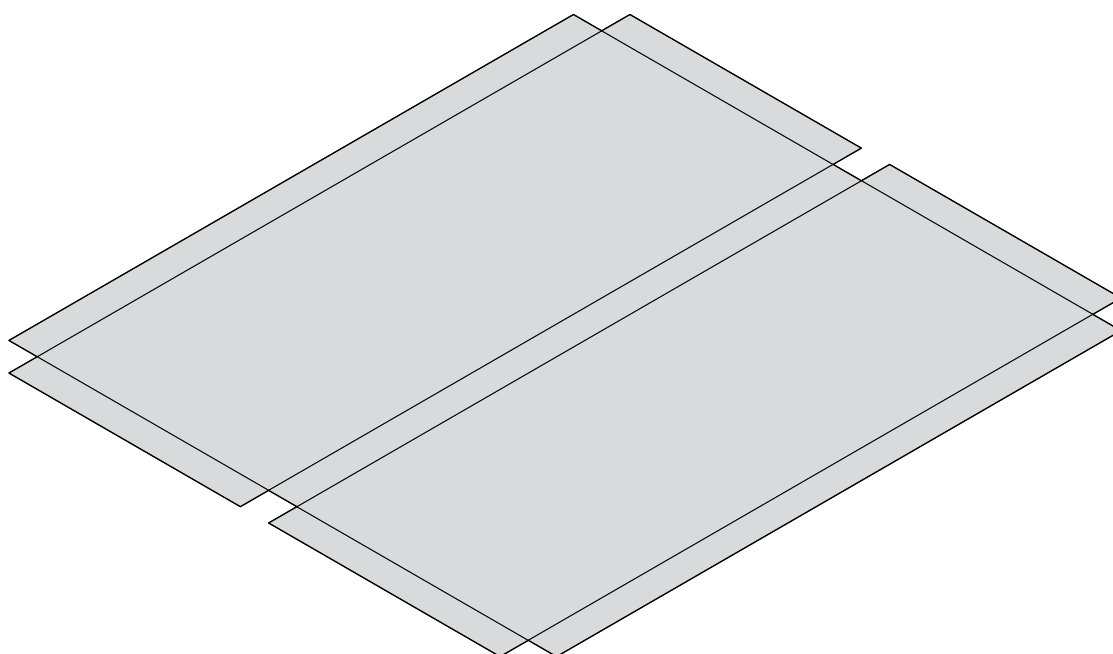

- DE Kartonverpackung unterlegen
- EN Underlay cardboard packaging

MONTAGE

ASSEMBLY



05

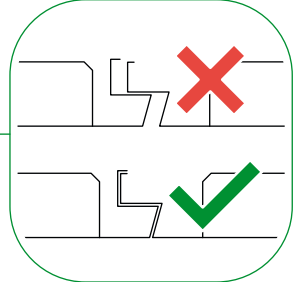
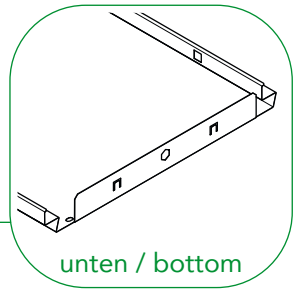
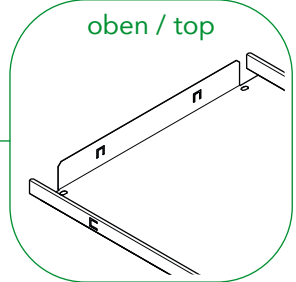
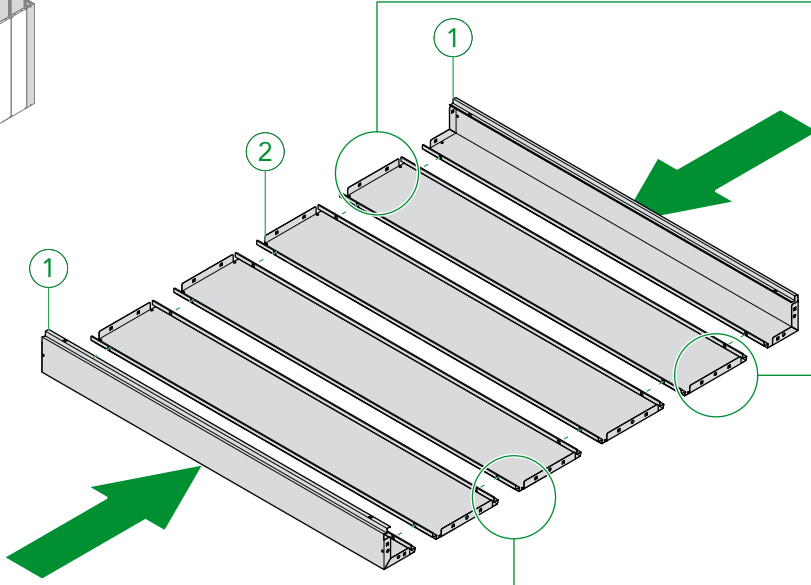
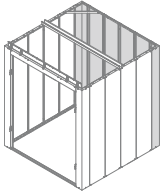

06

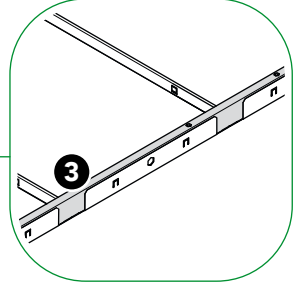
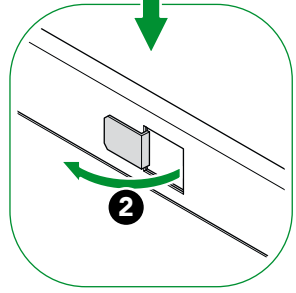
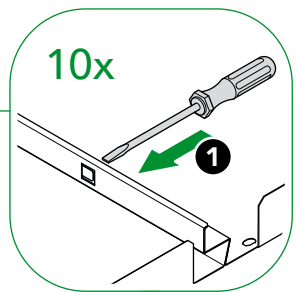
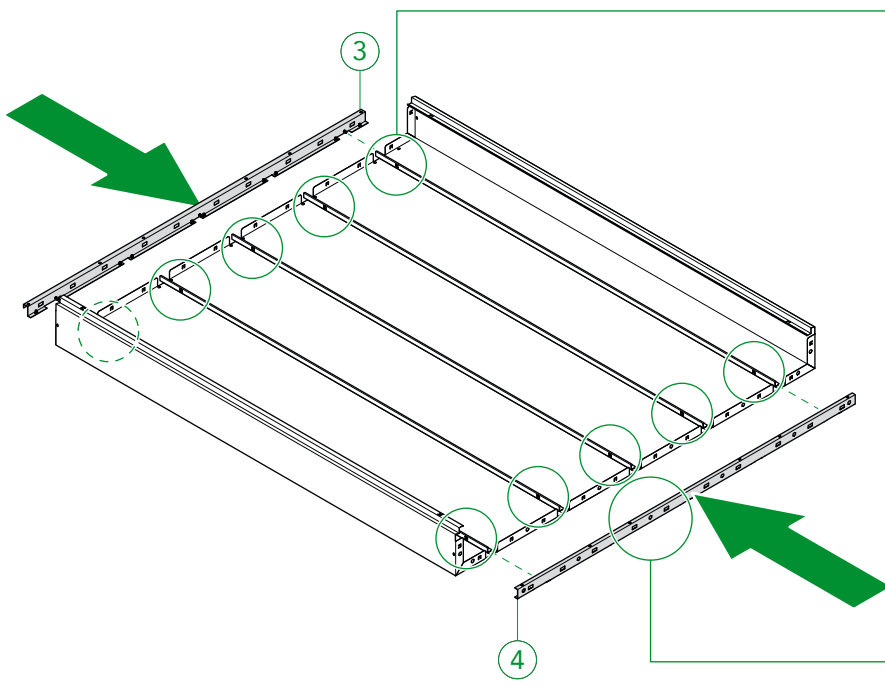

MONTAGE

ASSEMBLY



07

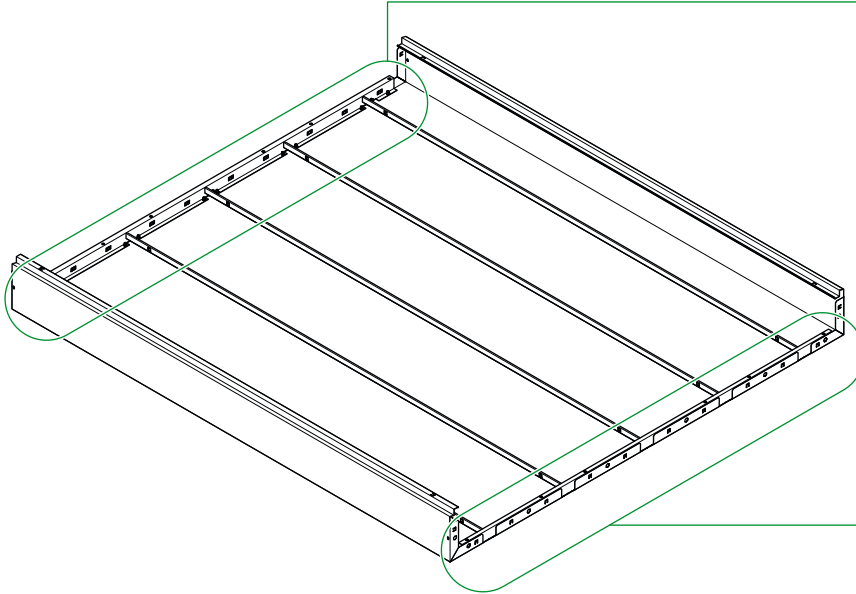

20x

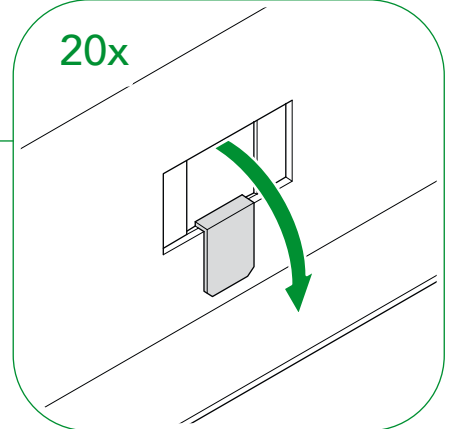

5

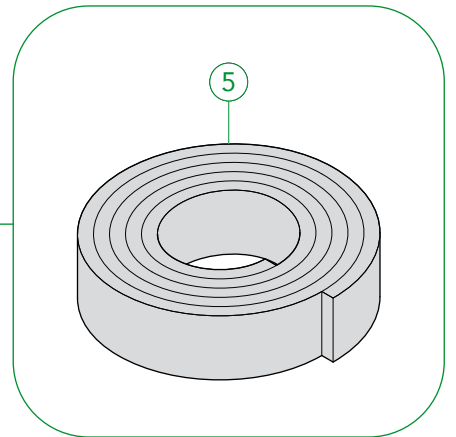

08

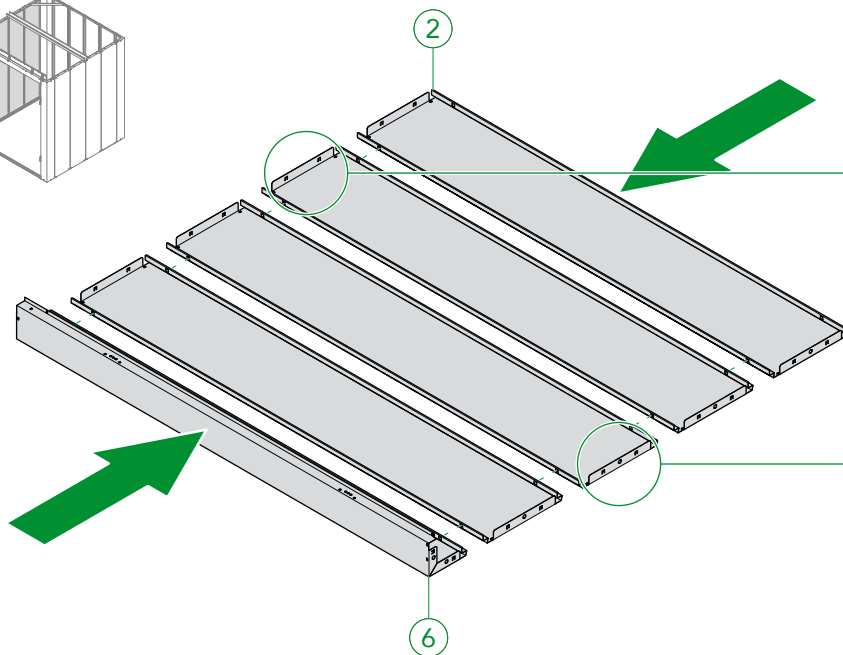
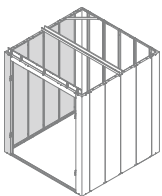

oben / top

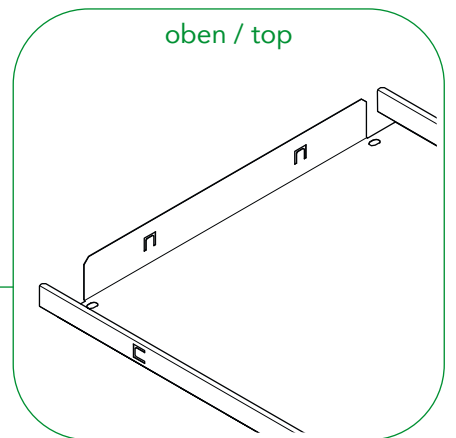

unten / bottom

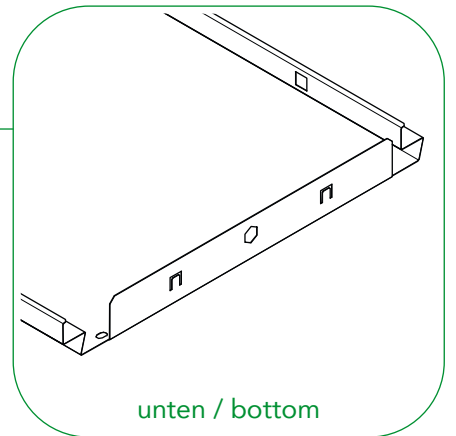

MONTAGE

ASSEMBLY



09

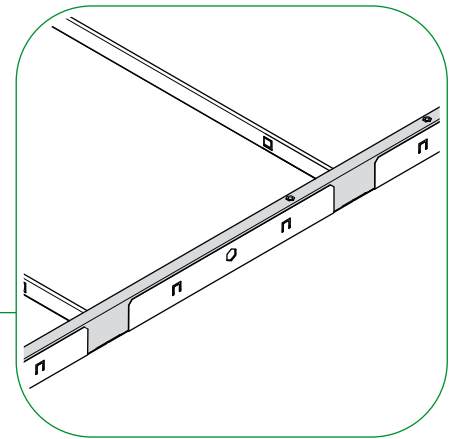
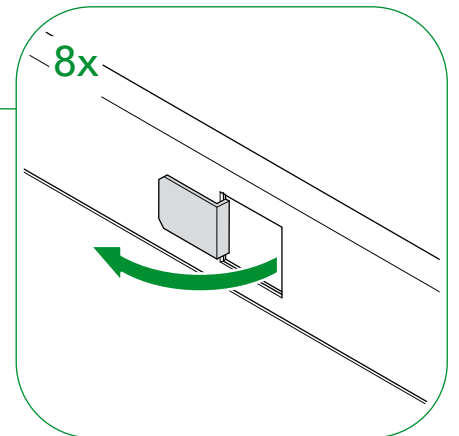
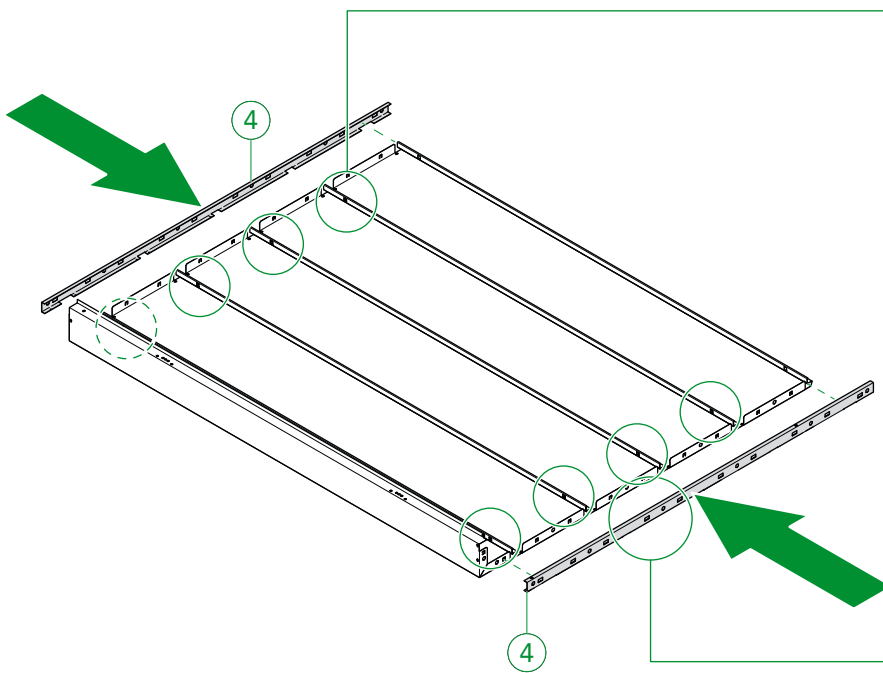

10

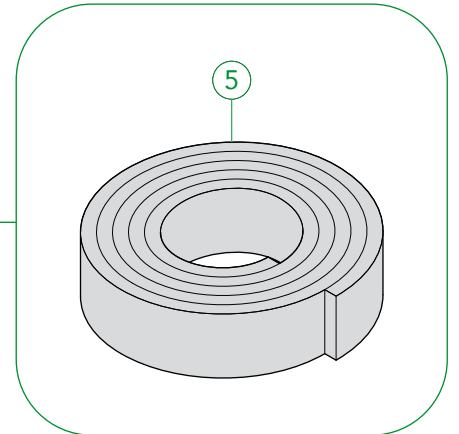
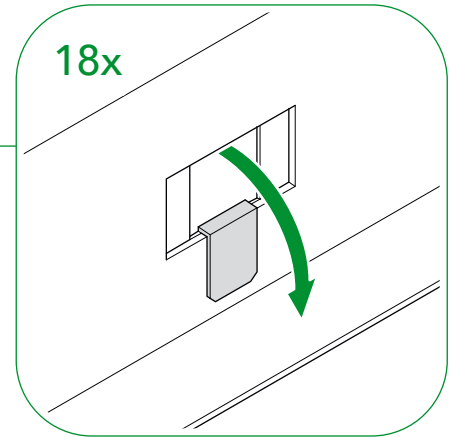
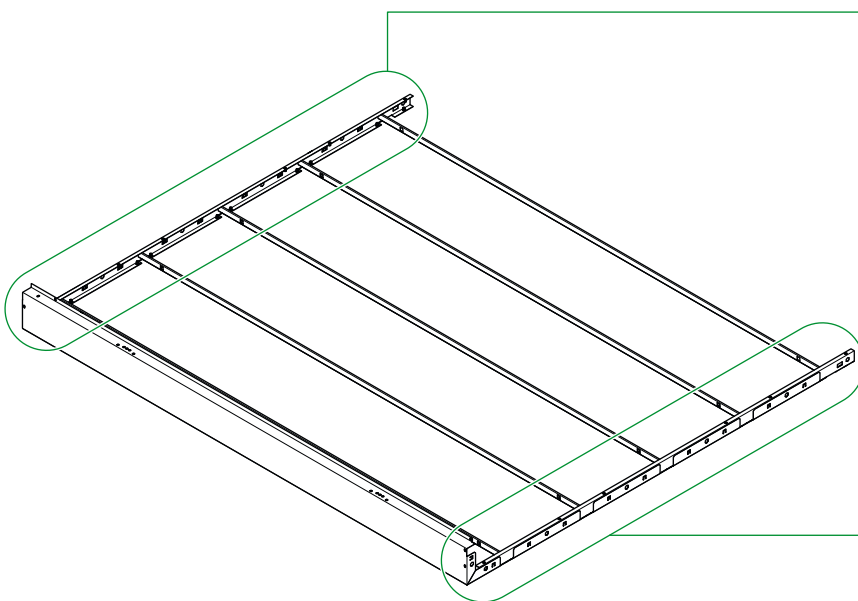

11

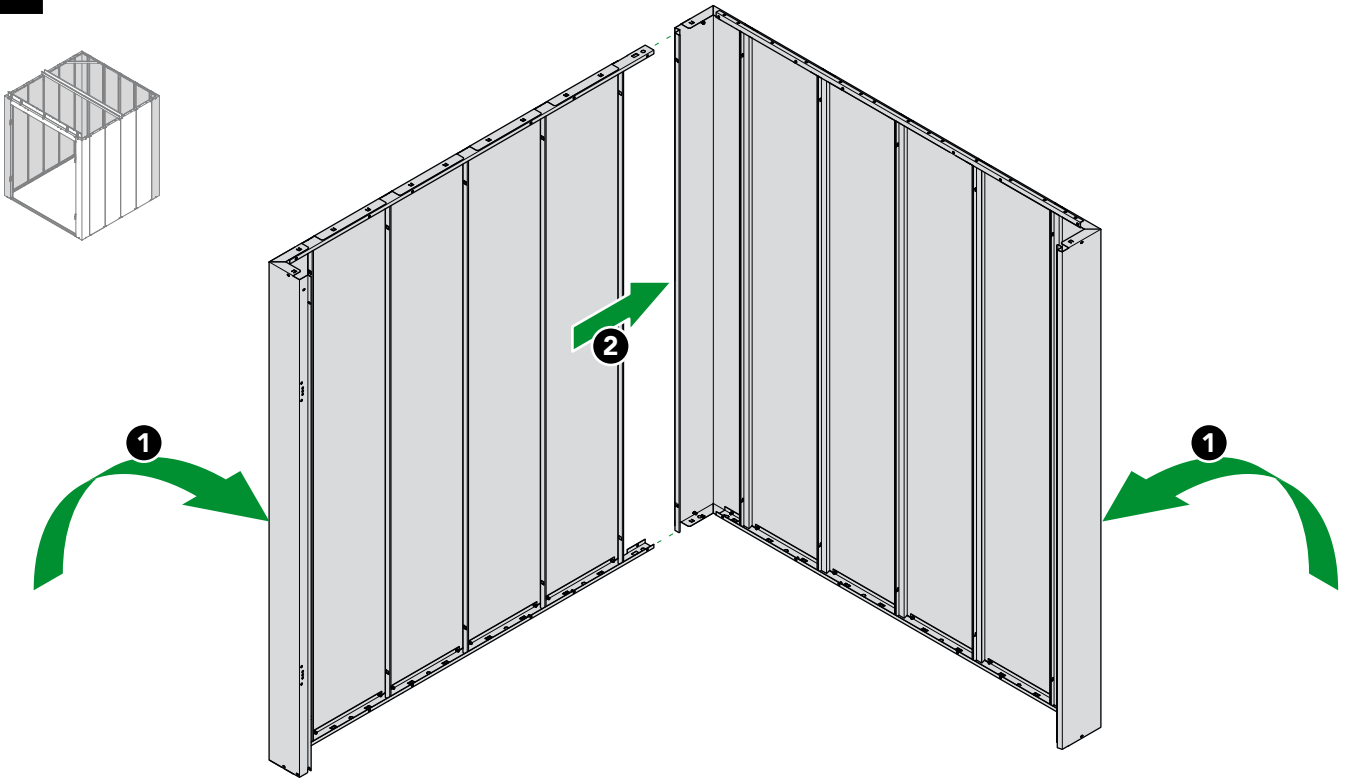

12

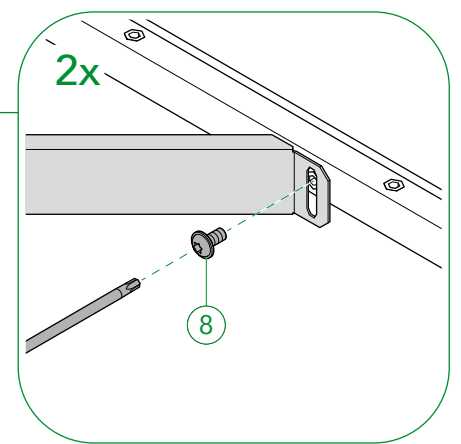
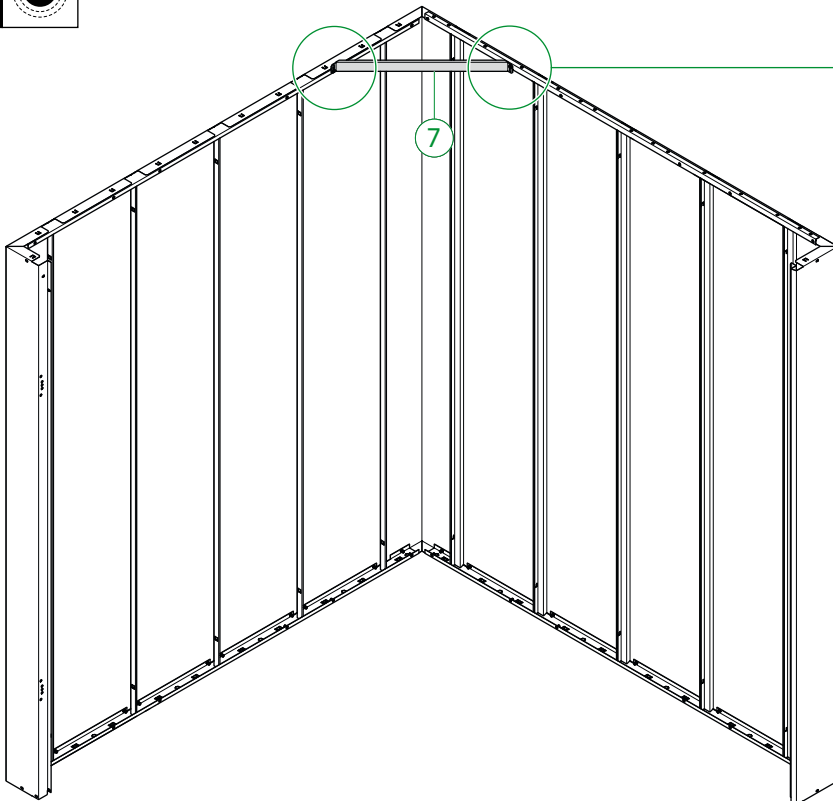

13

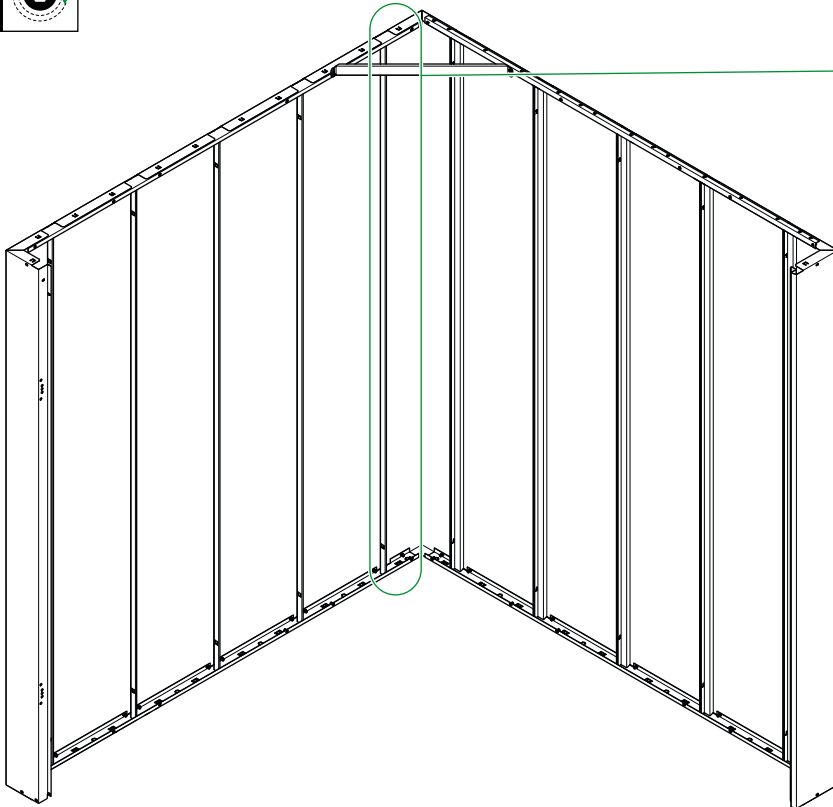

4x

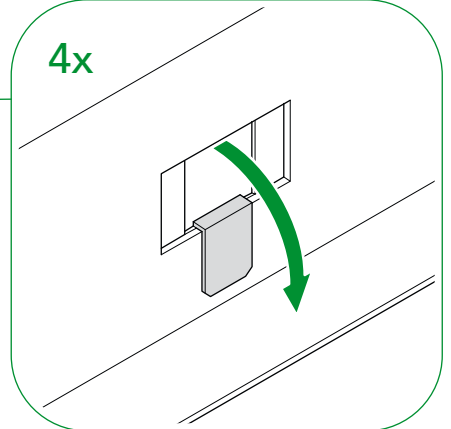

2x

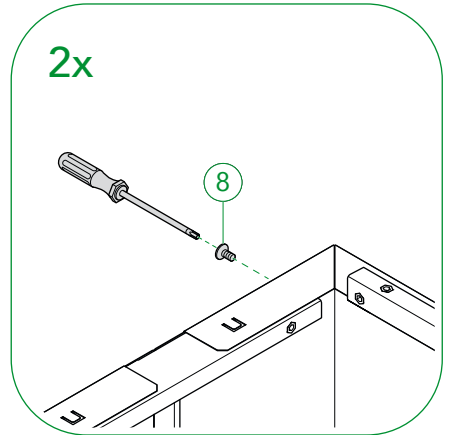

14

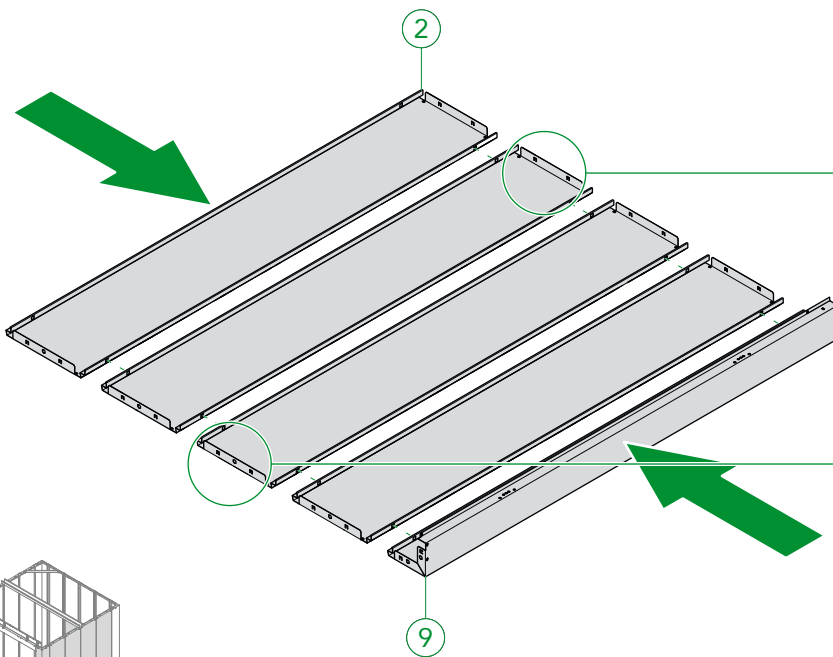

oben / top

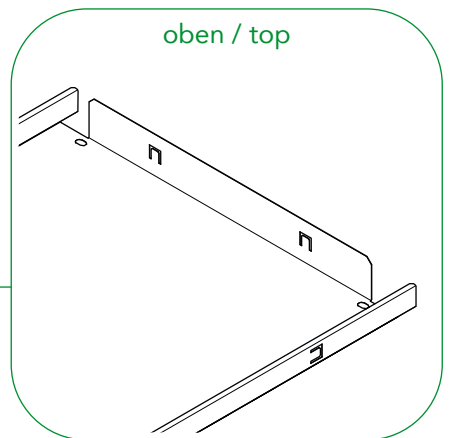

unten / bottom

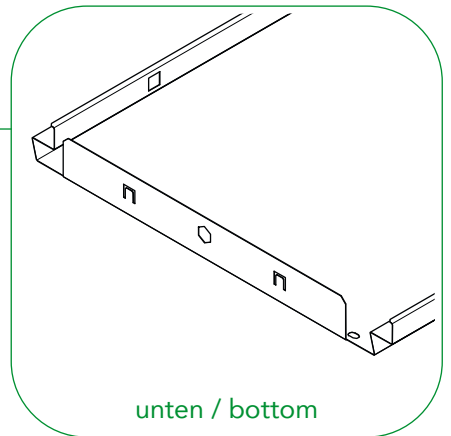

15

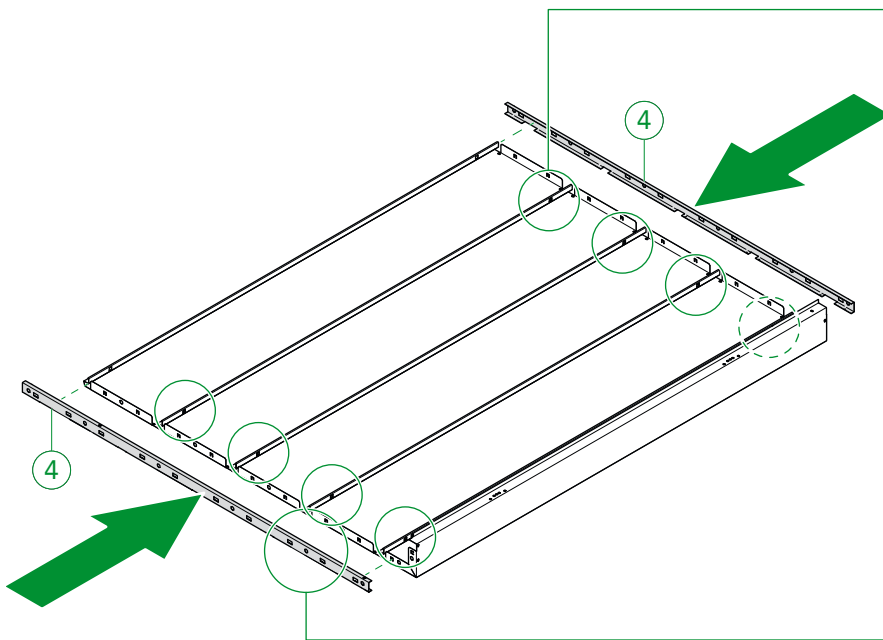

8x

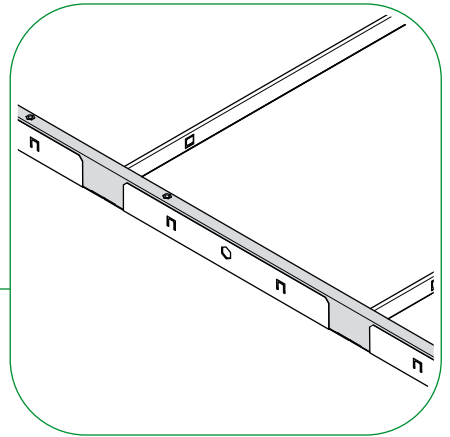
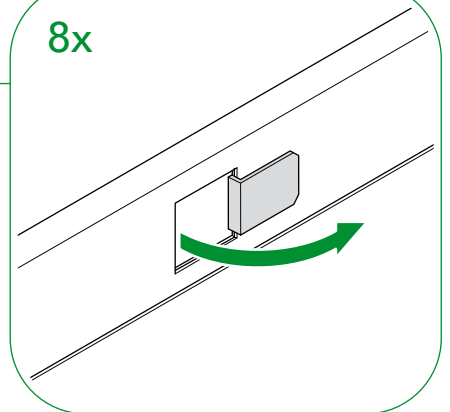

16

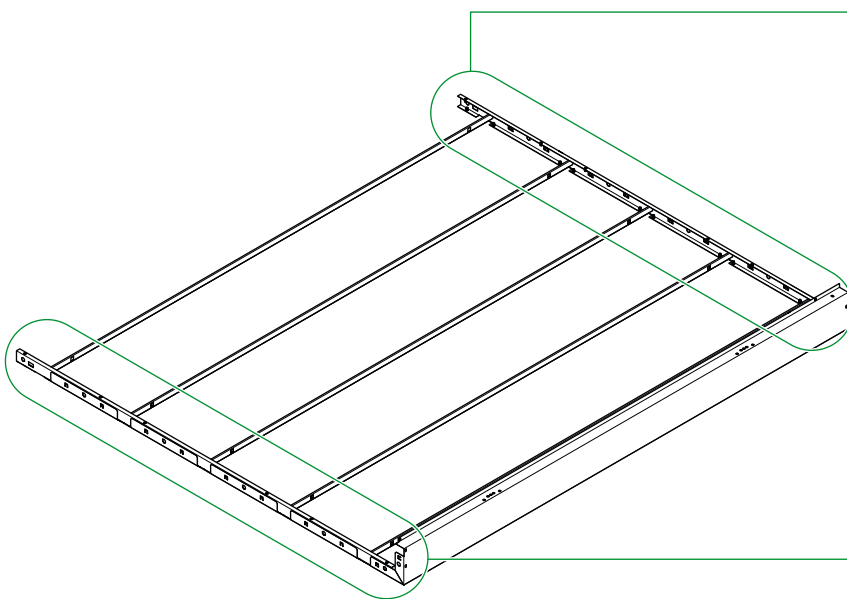

18x

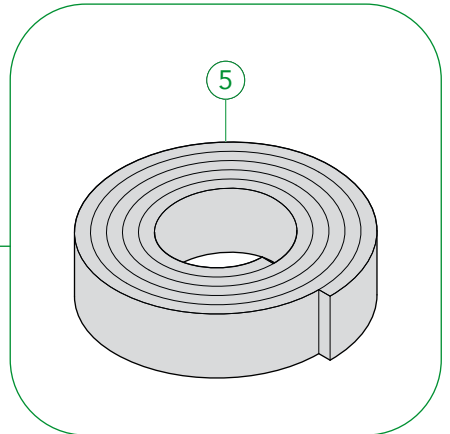
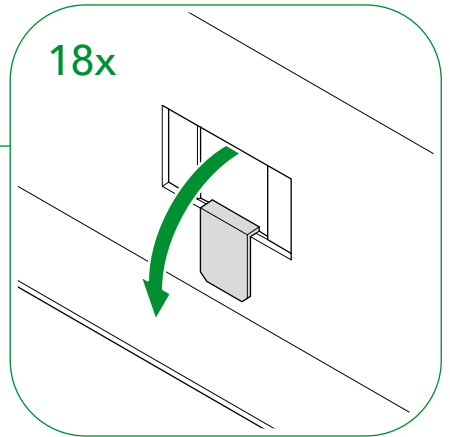

17

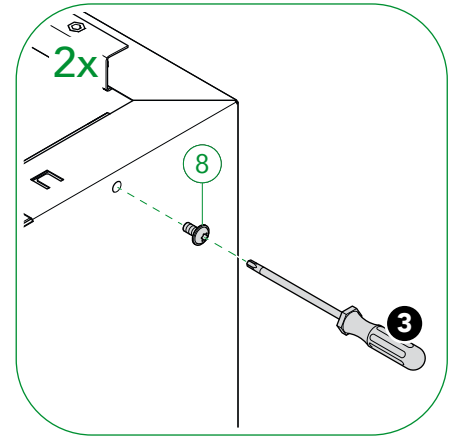
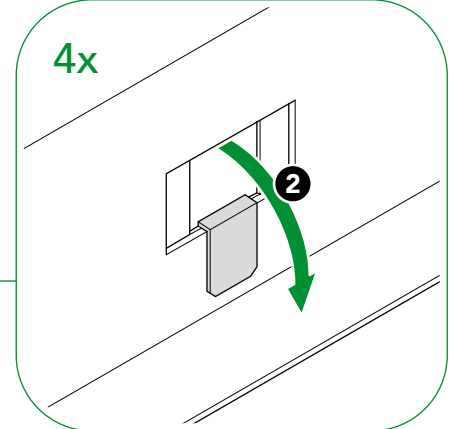
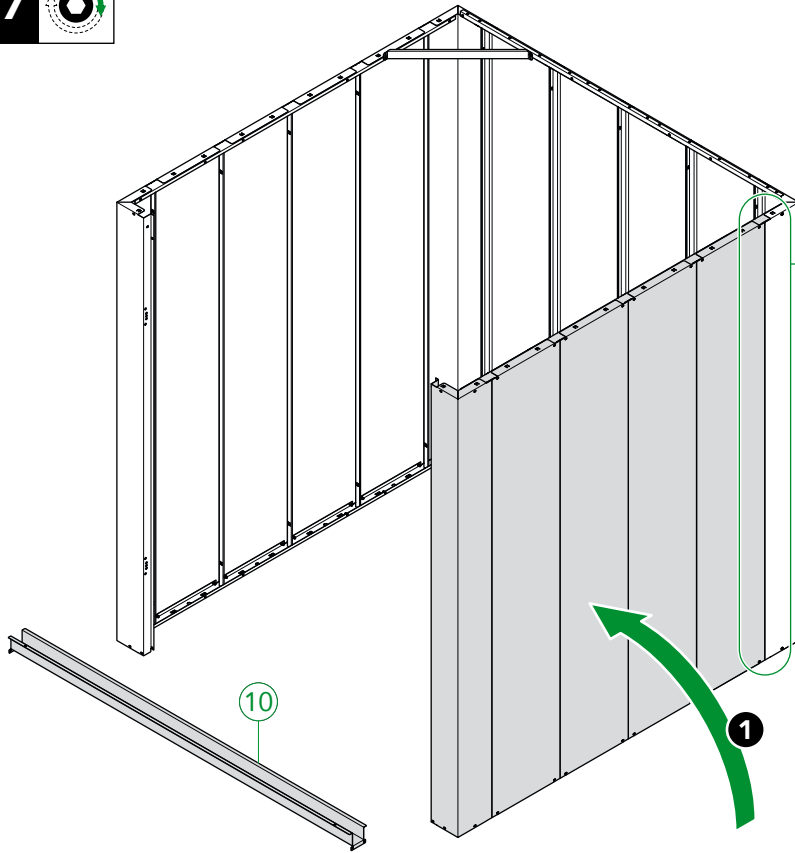

18

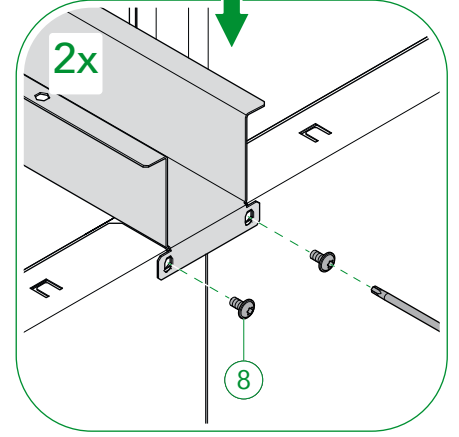
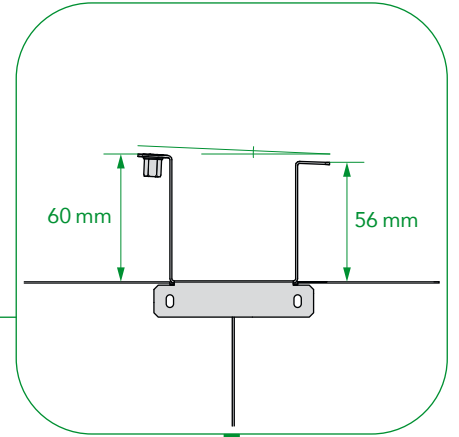
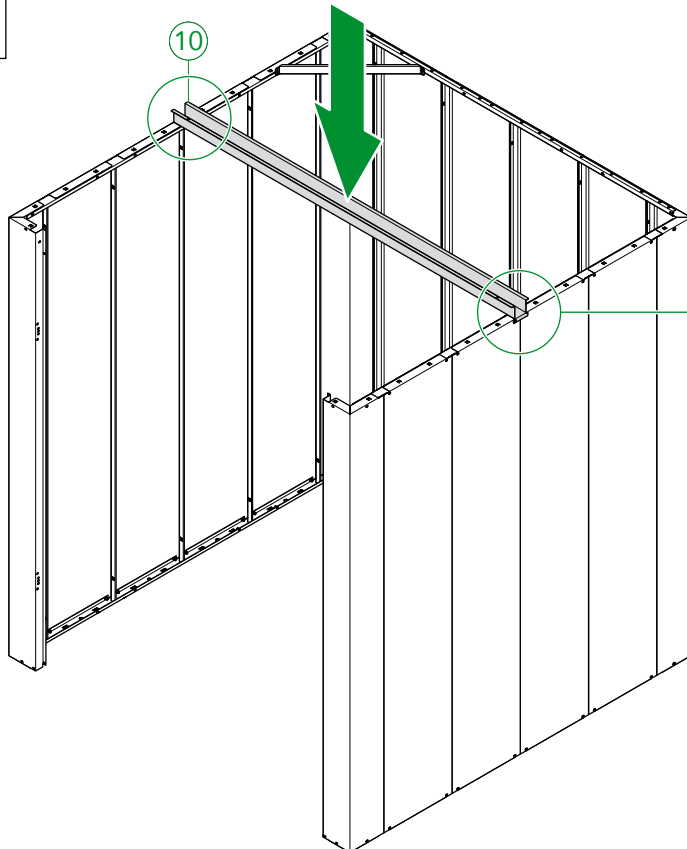

MONTAGE

ASSEMBLY

19

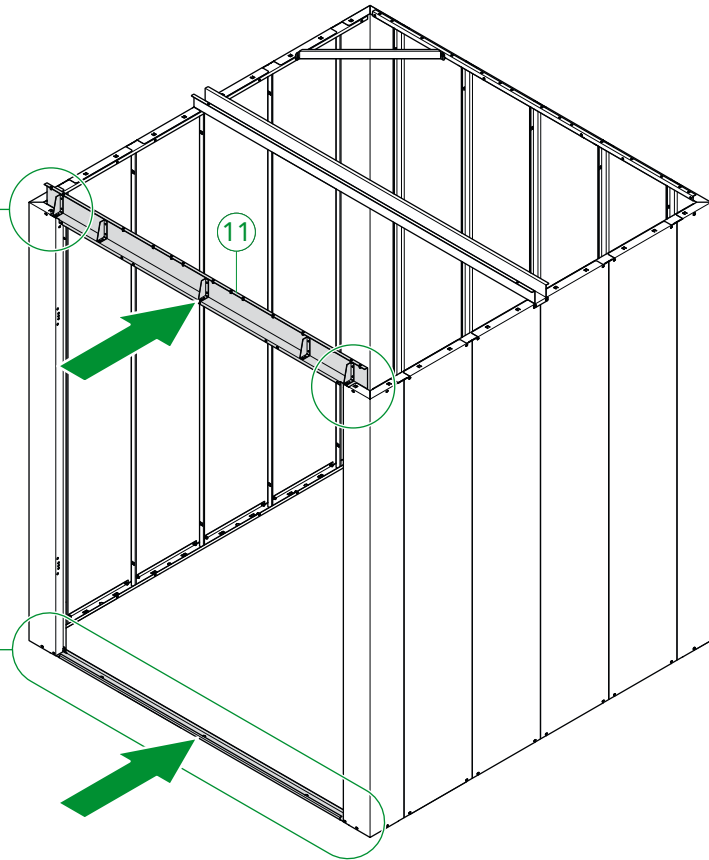
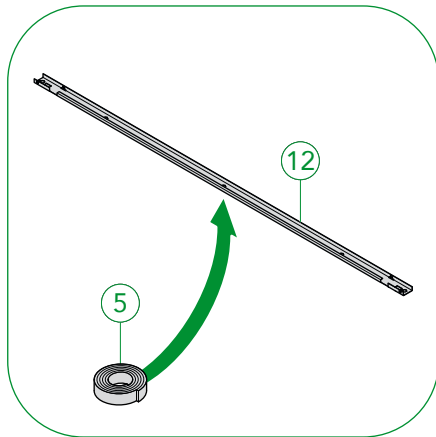
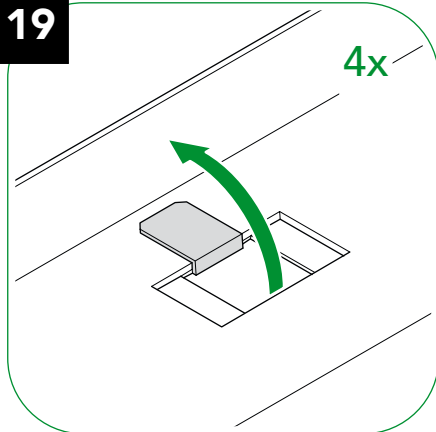

20

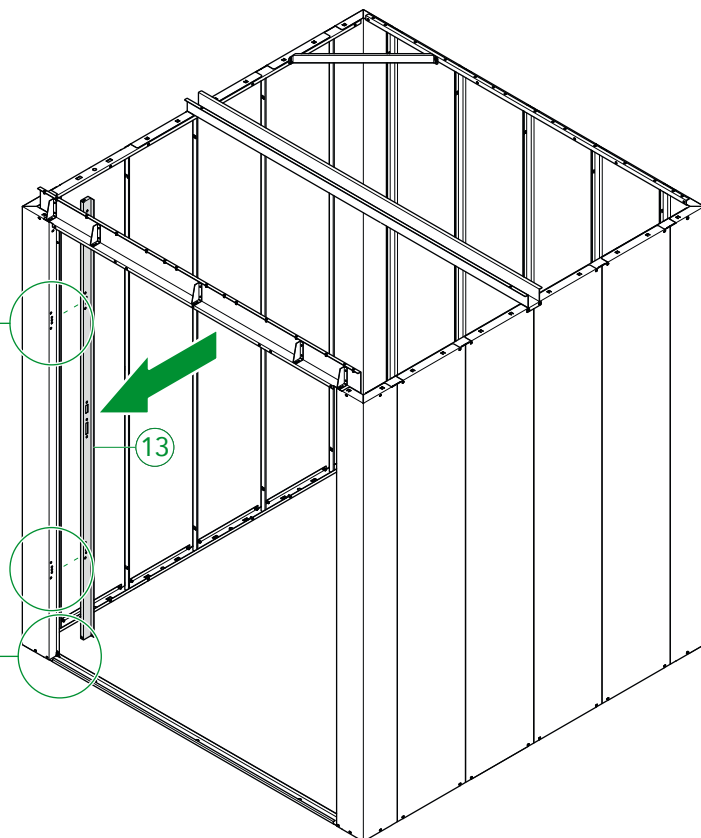
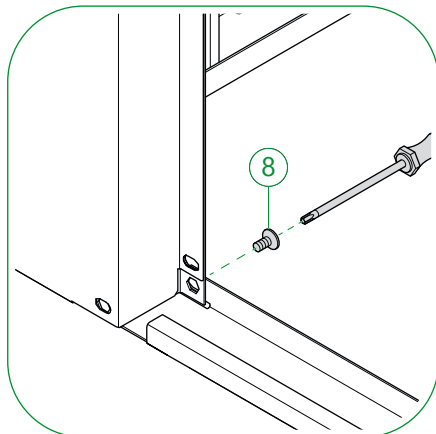
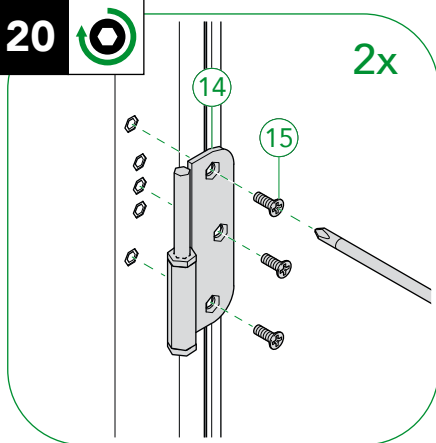

21 

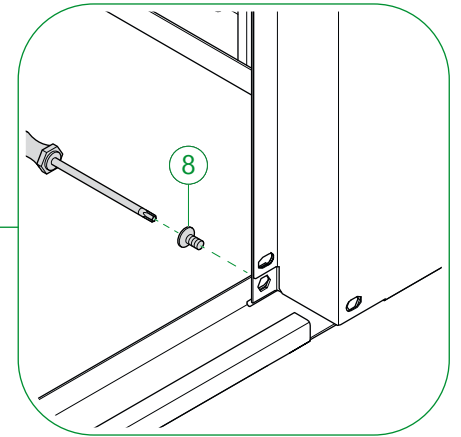
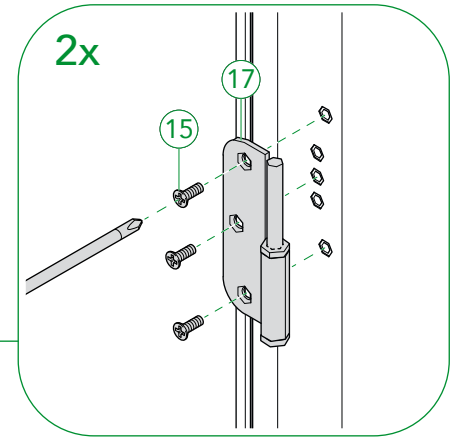
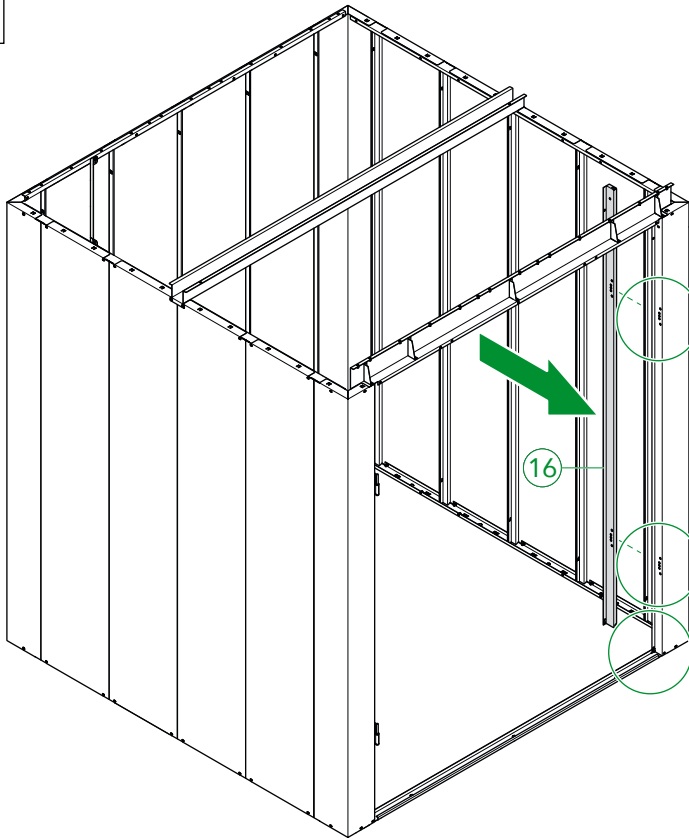

22 

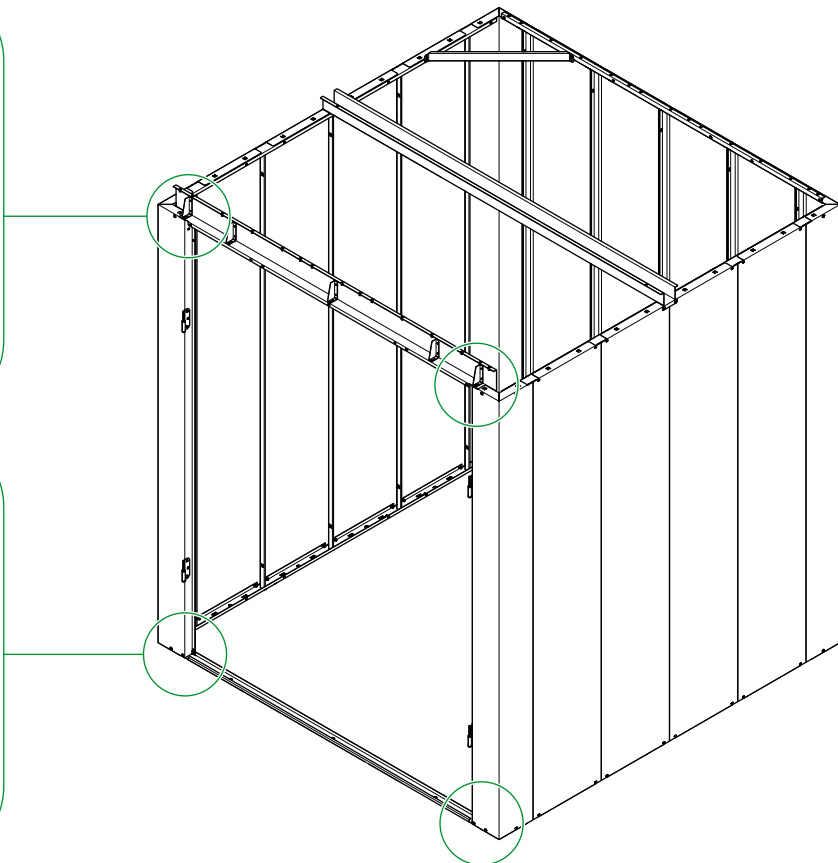
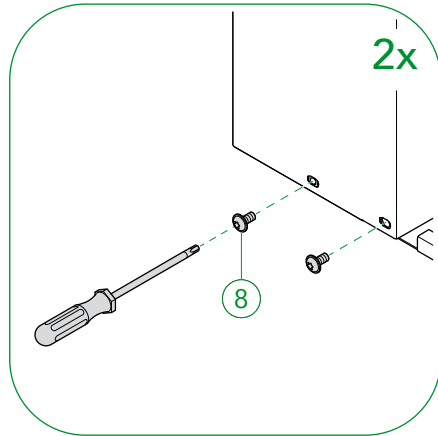
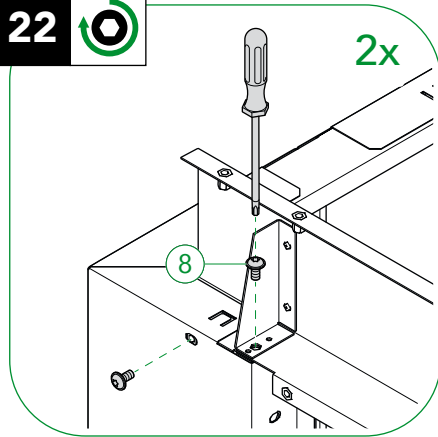

MONTAGE

ASSEMBLY

23

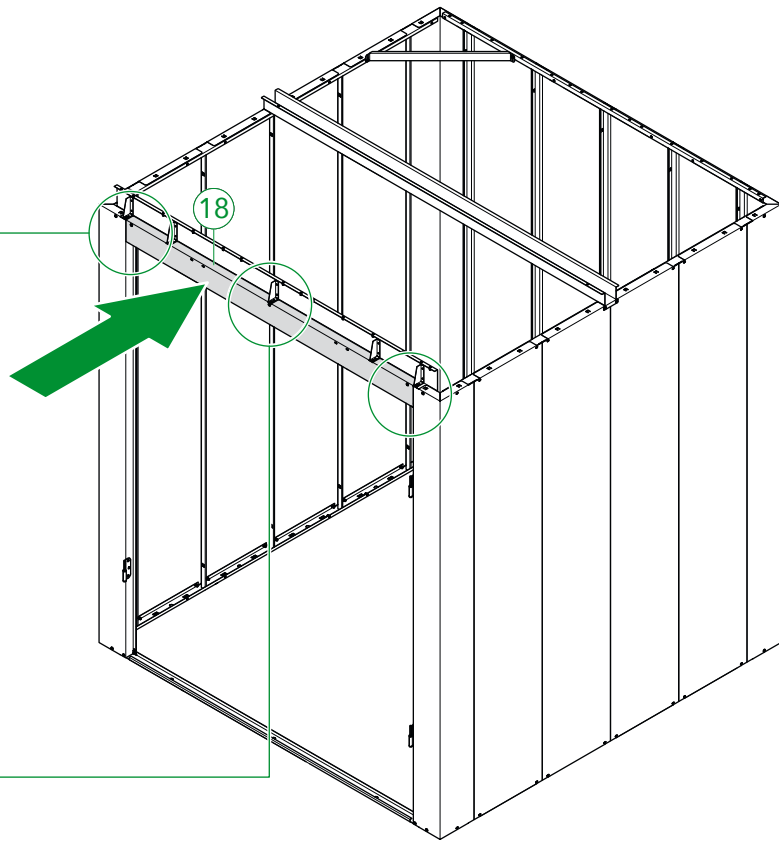
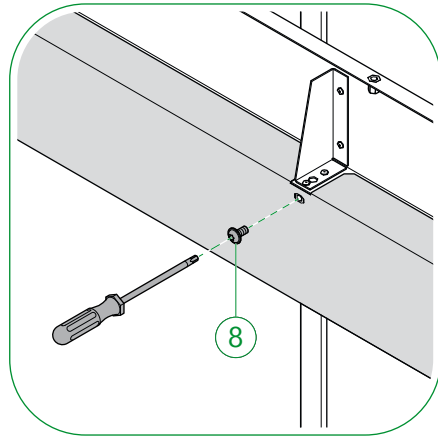
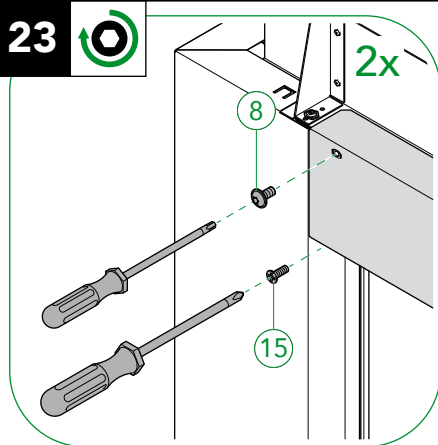

24

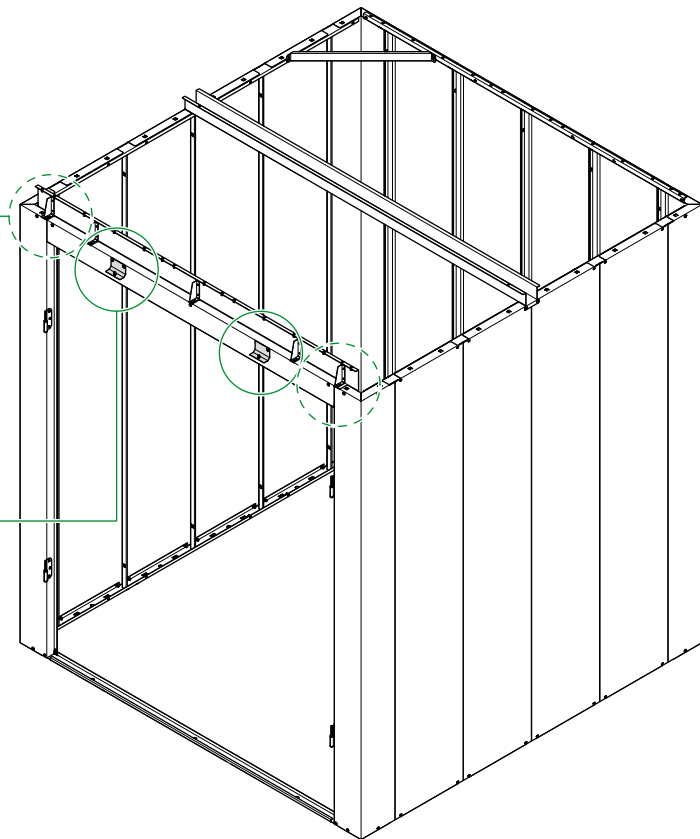
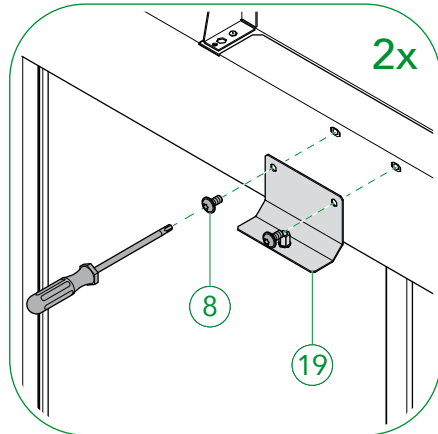
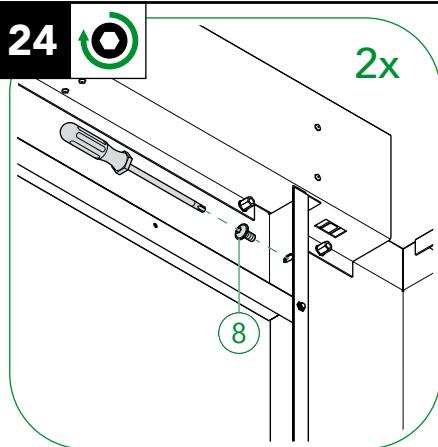

25

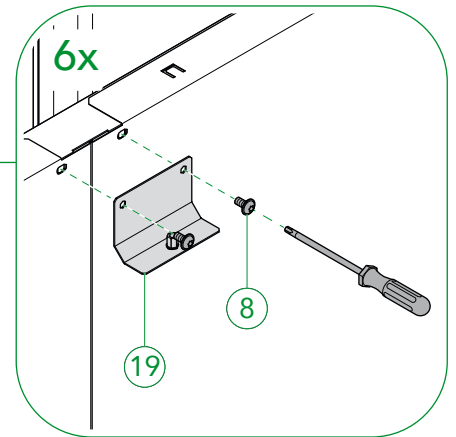
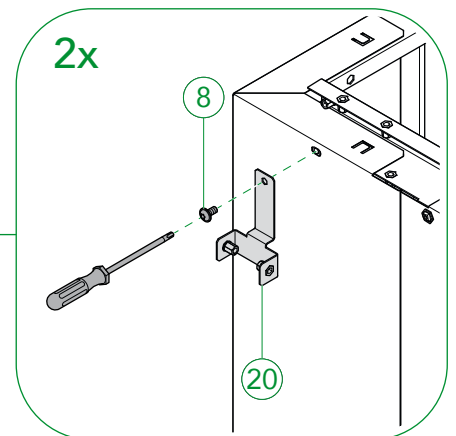
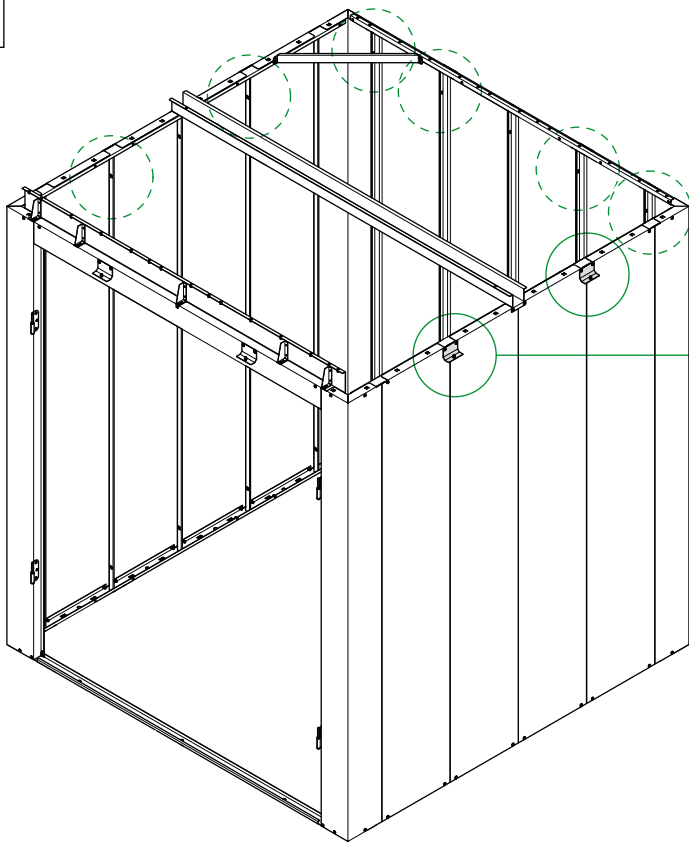

26

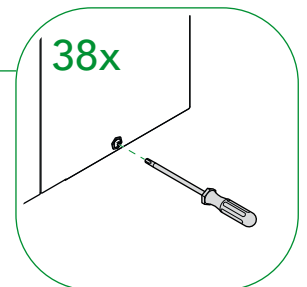
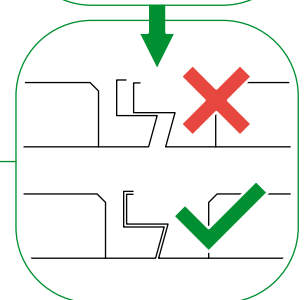
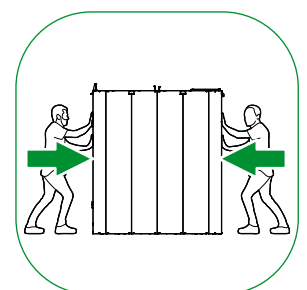
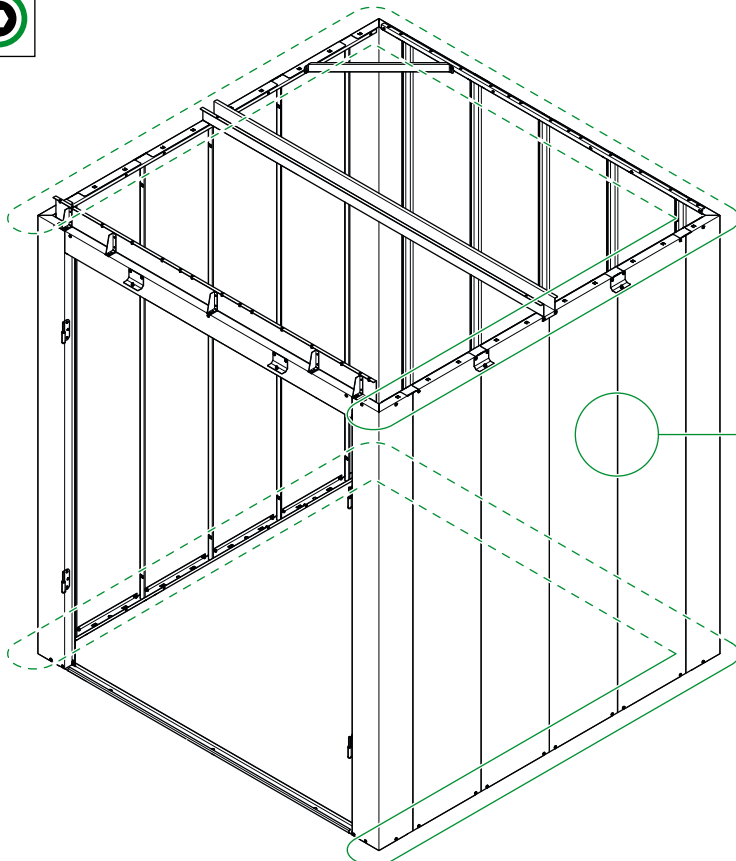

27 

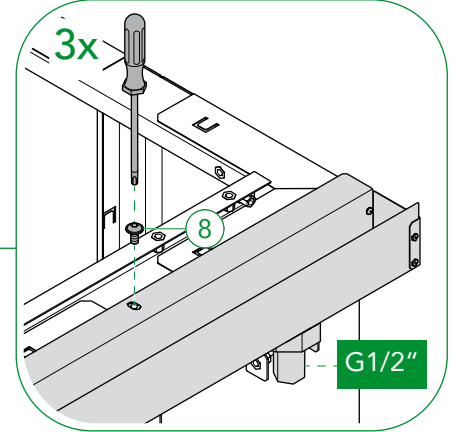
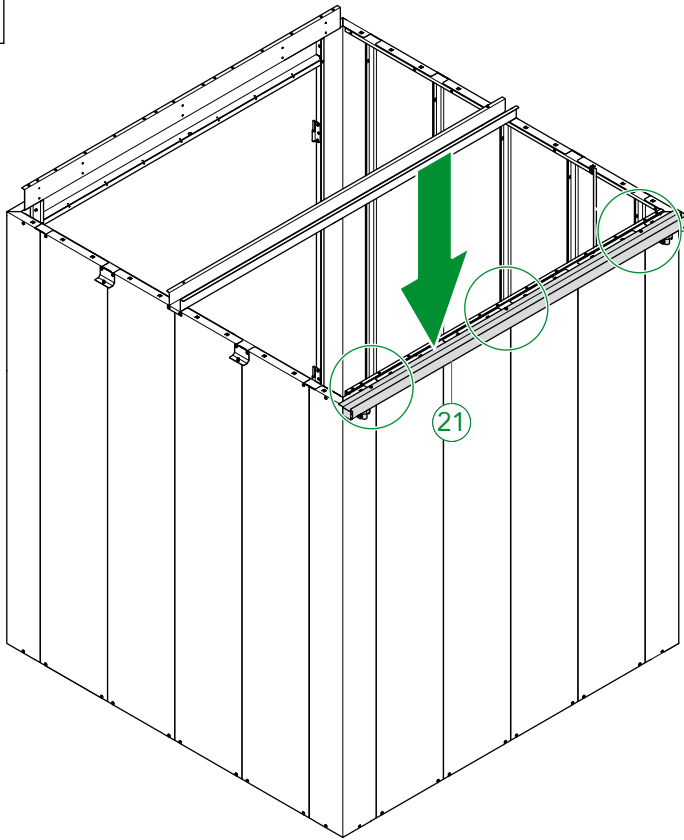

28 

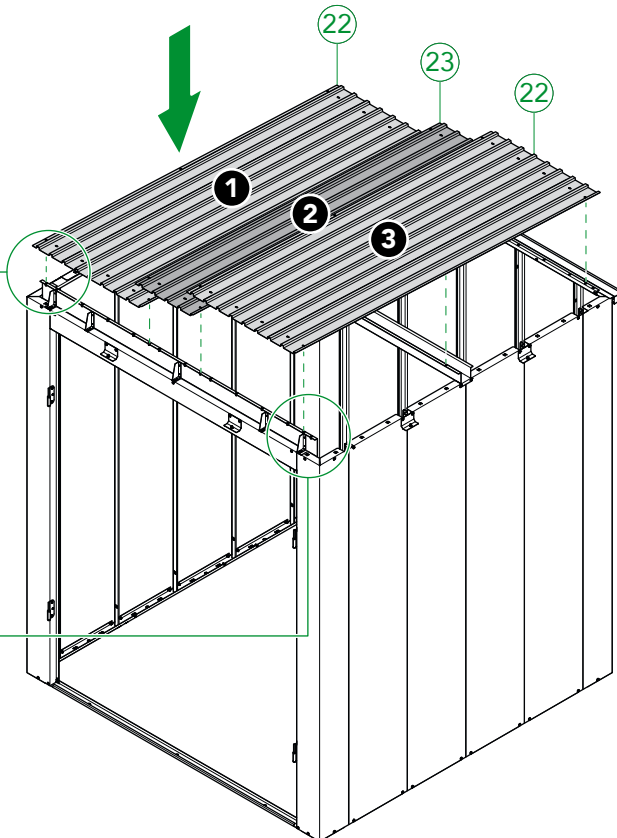
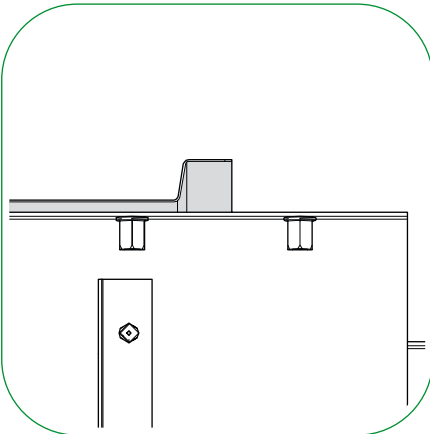
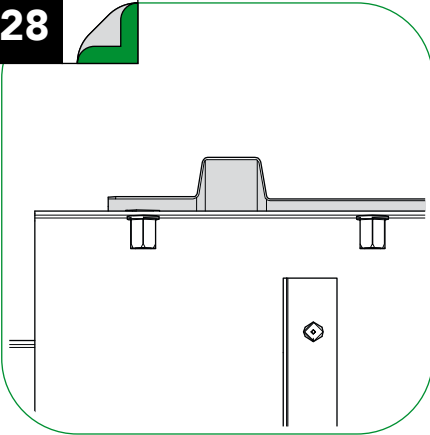

29 

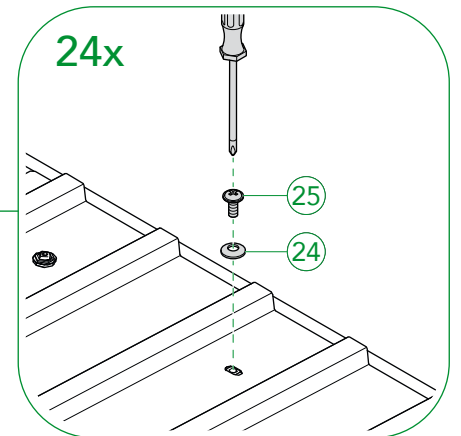
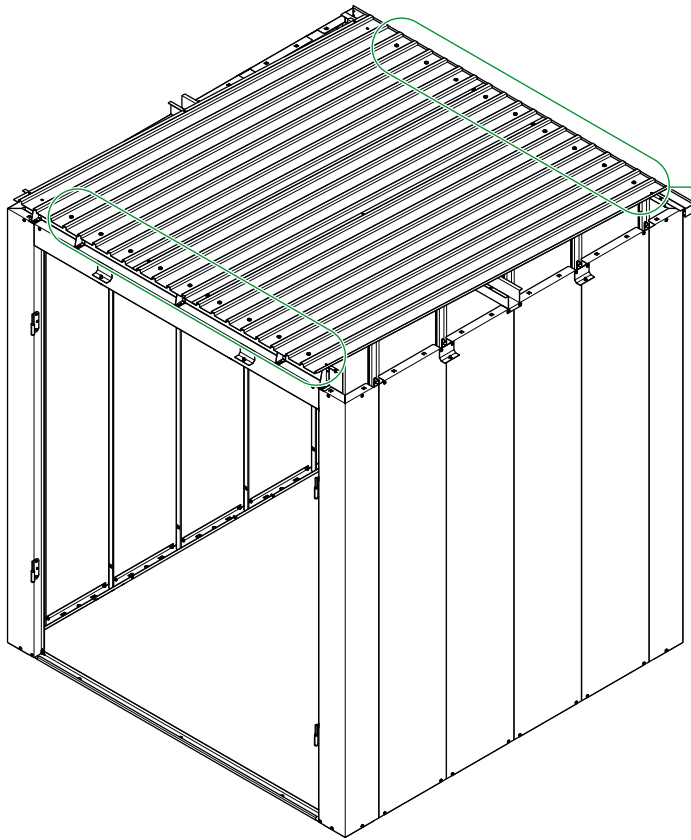

30  

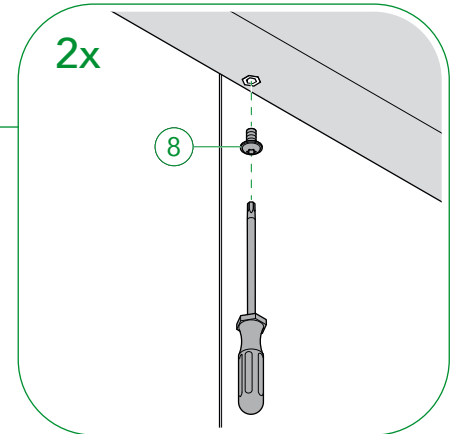
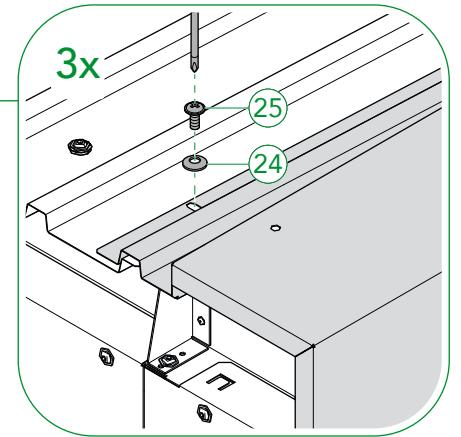
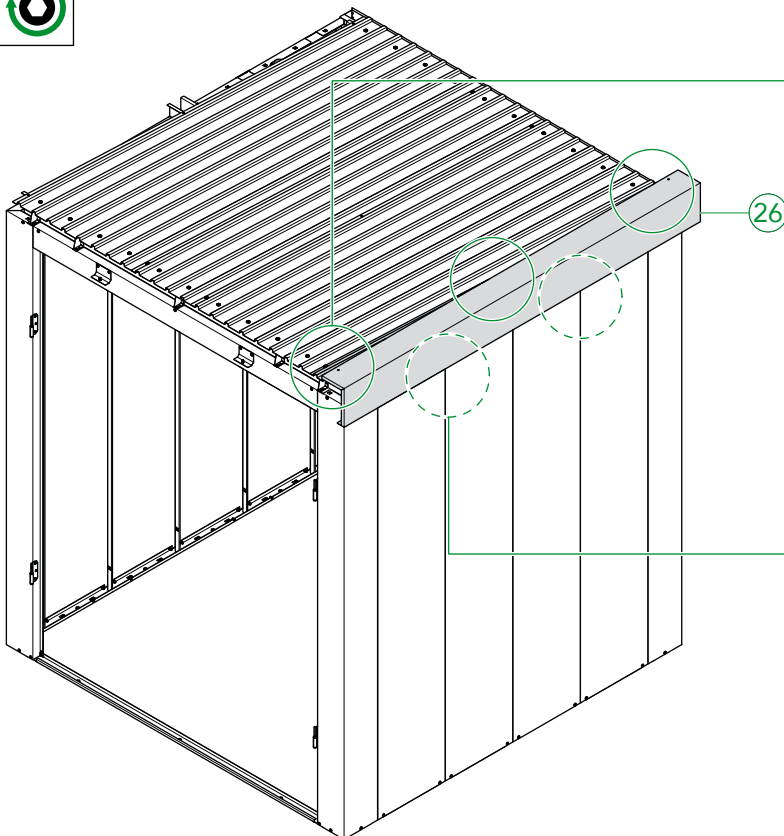

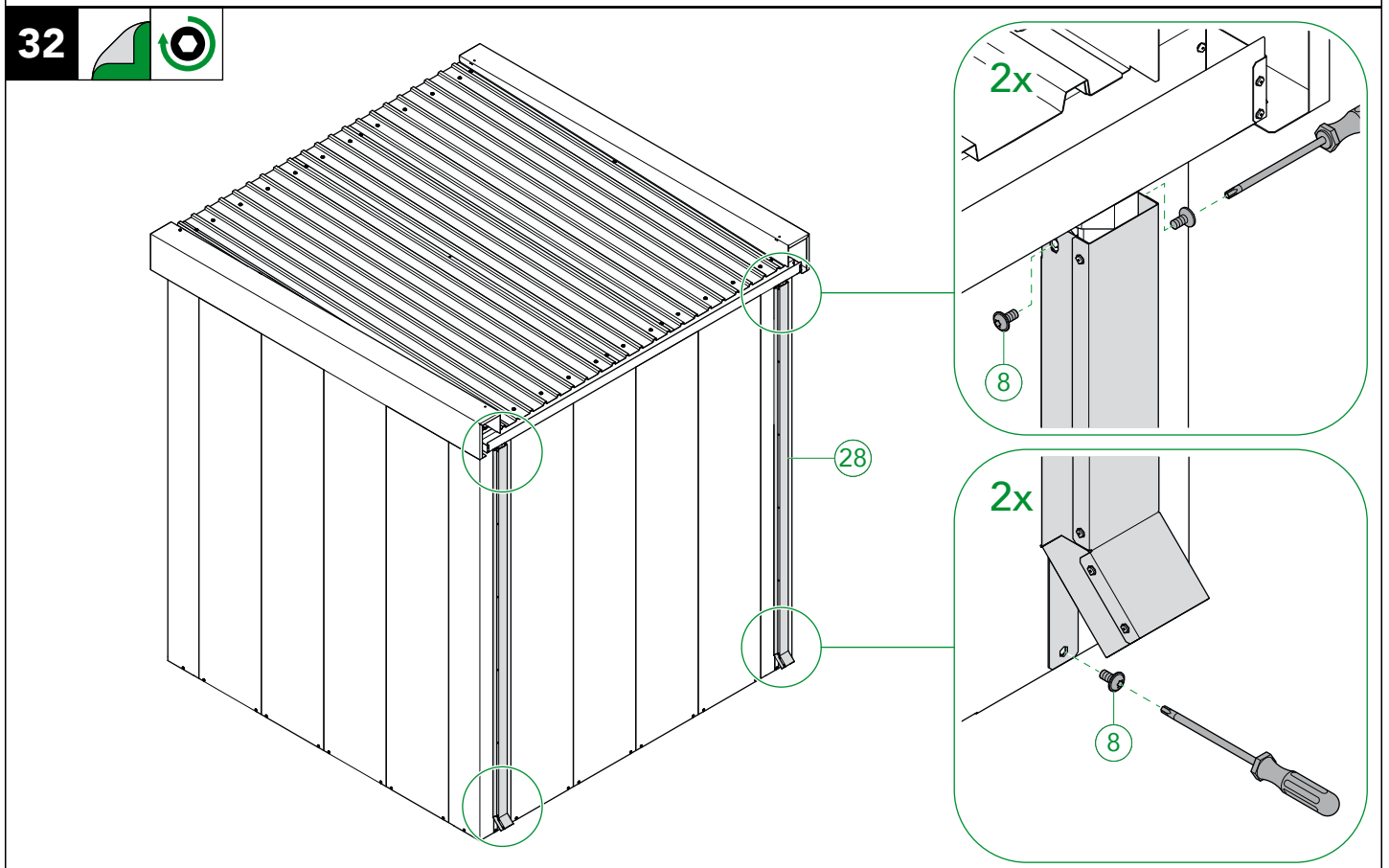
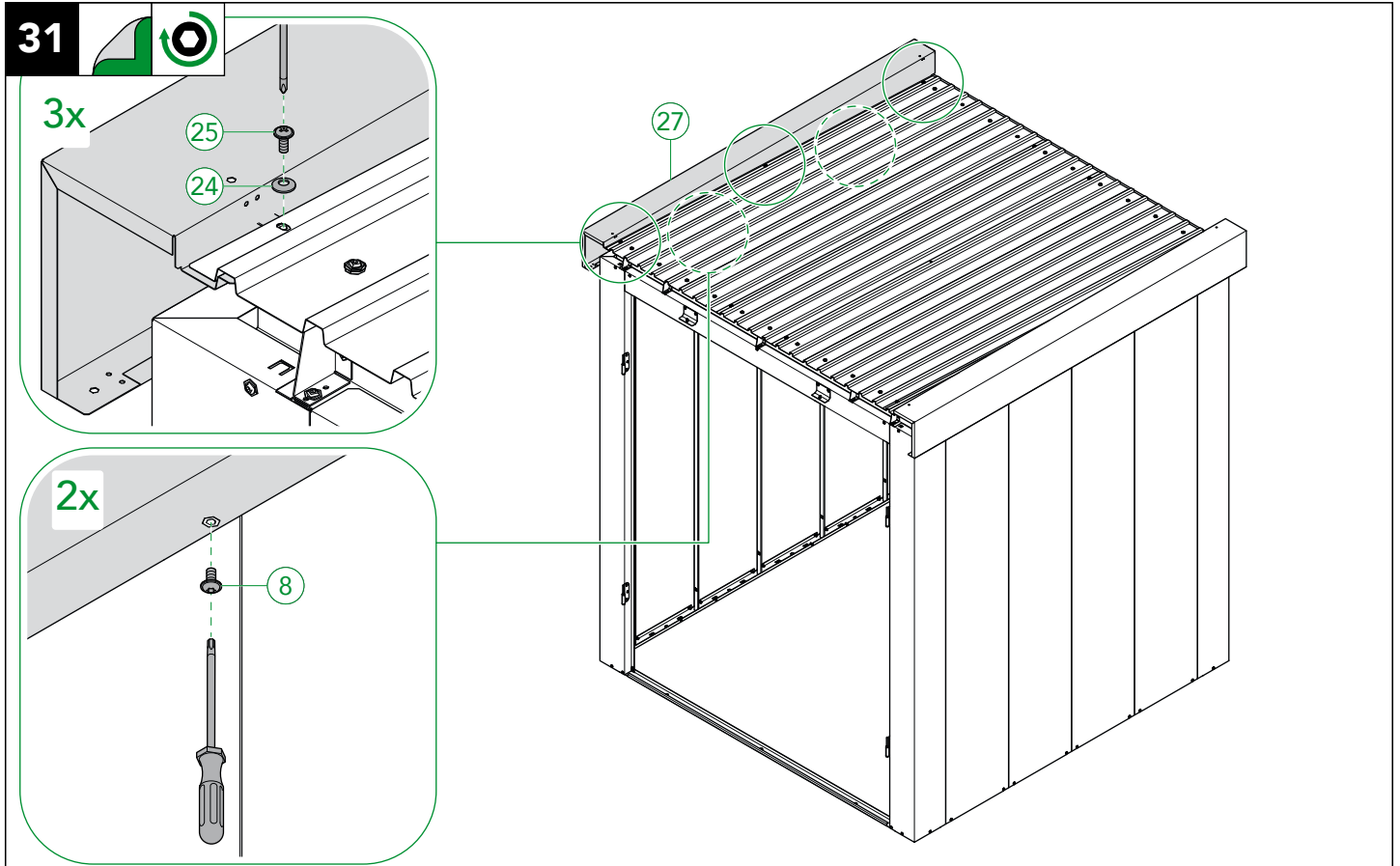

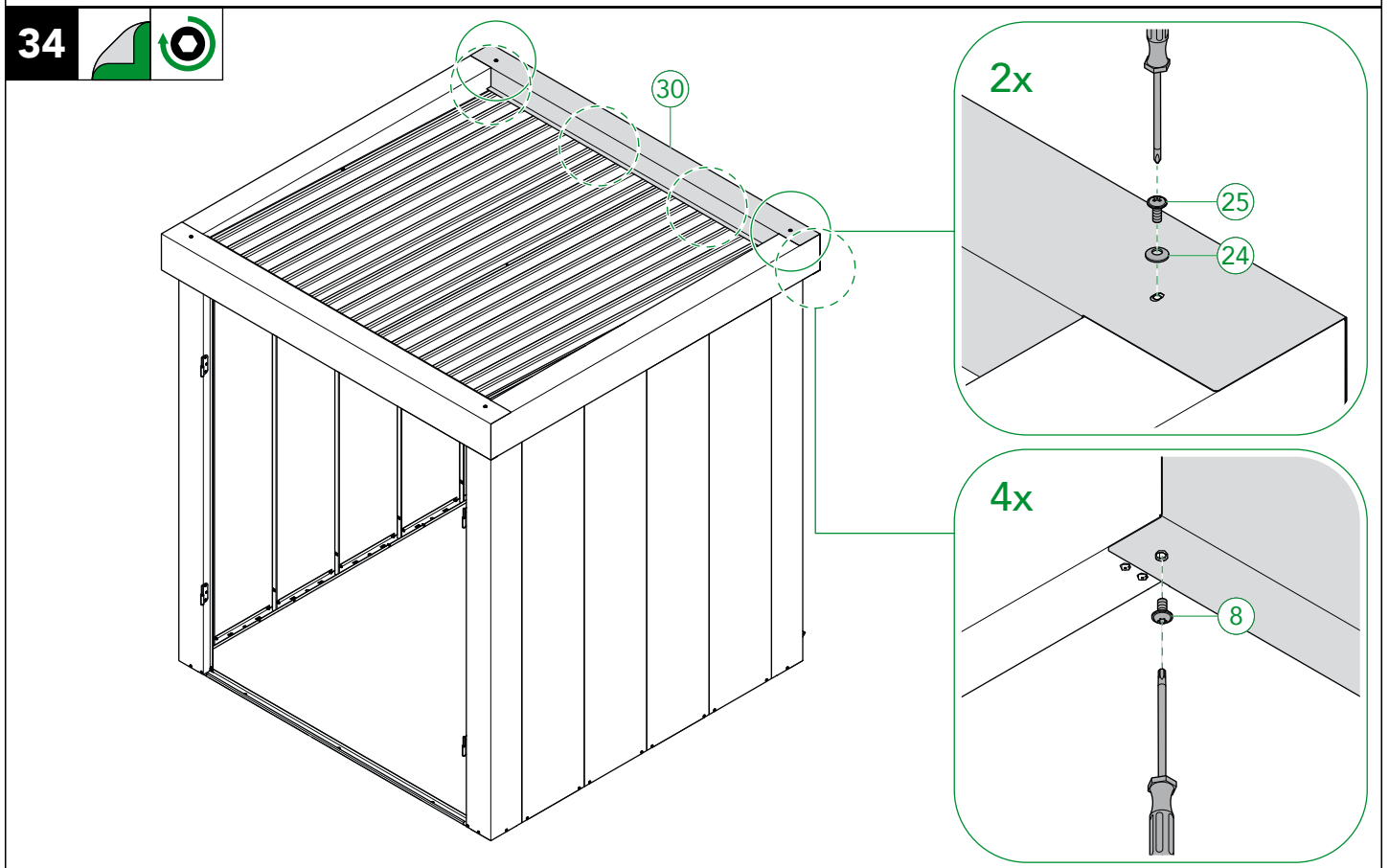
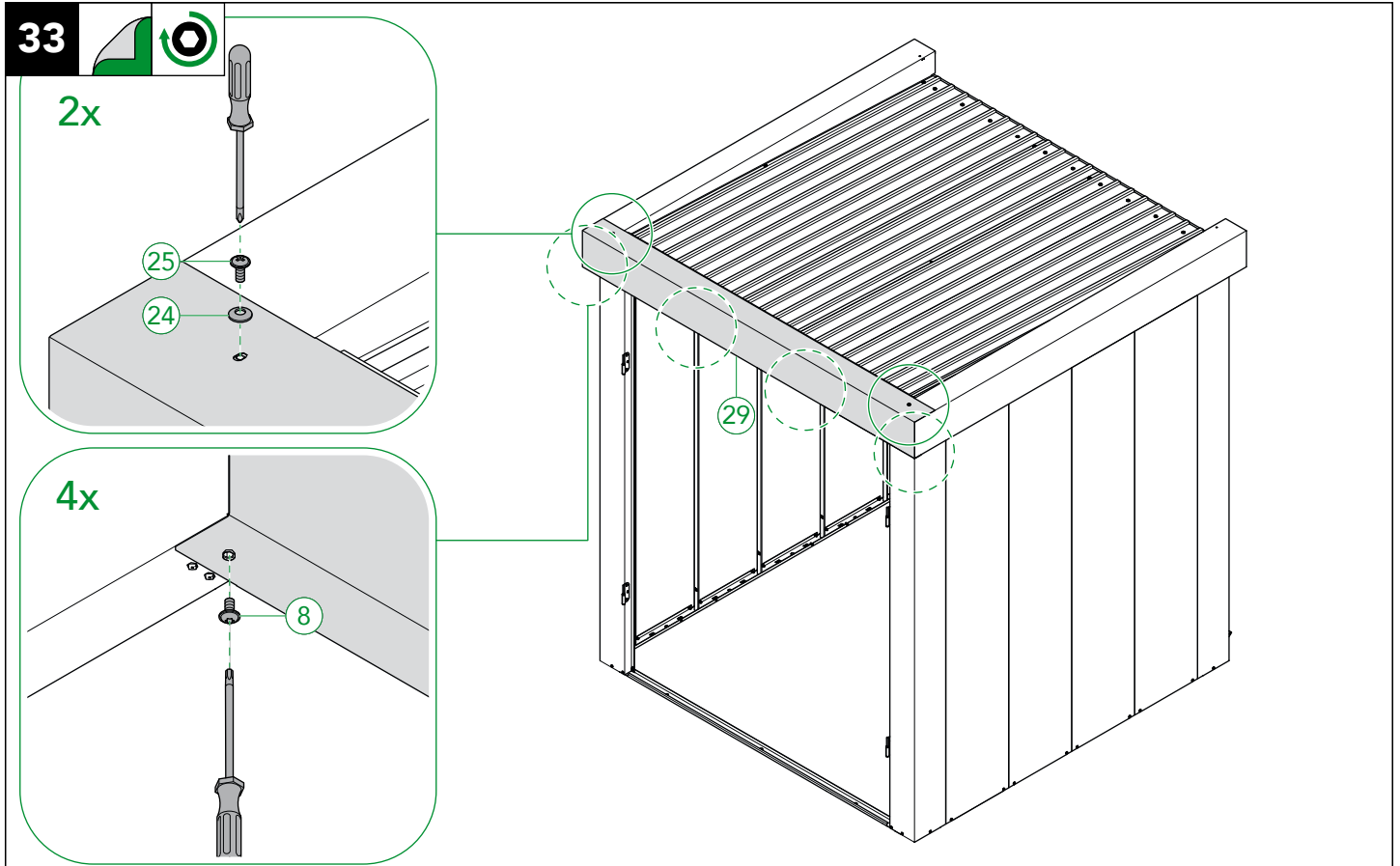

MONTAGE

ASSEMBLY

35 

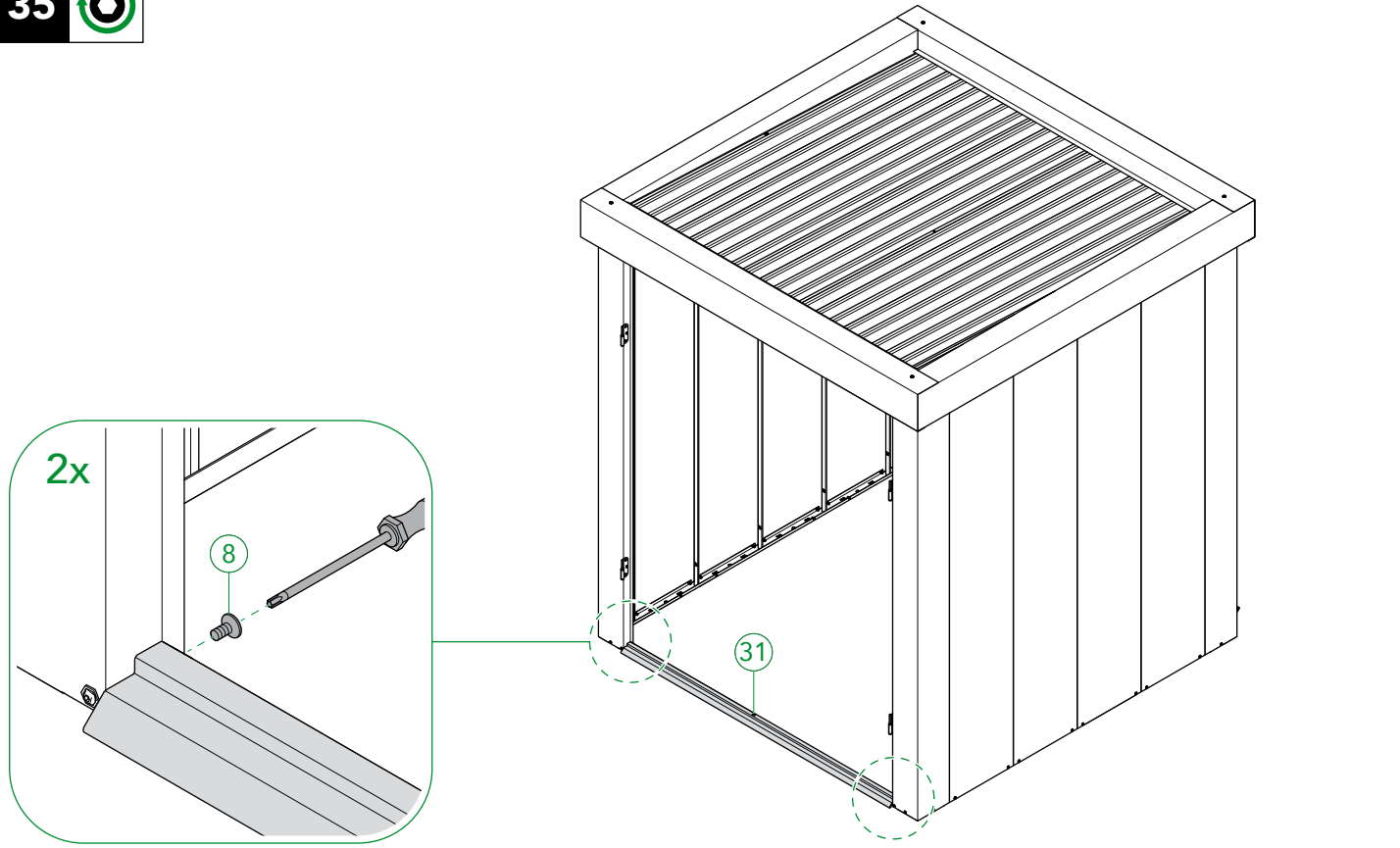

36  

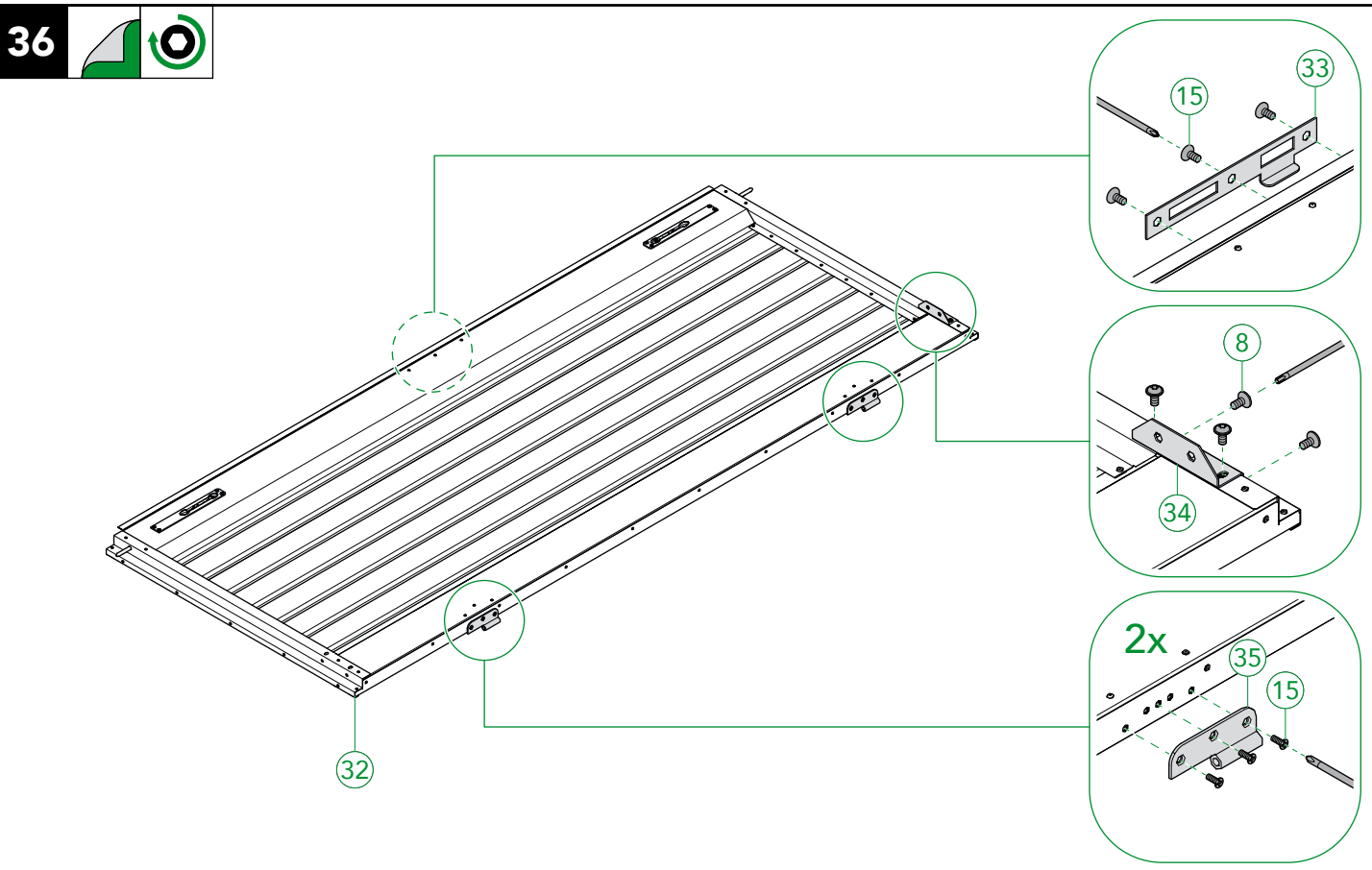

37

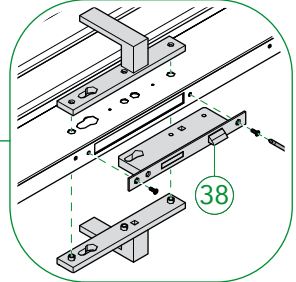
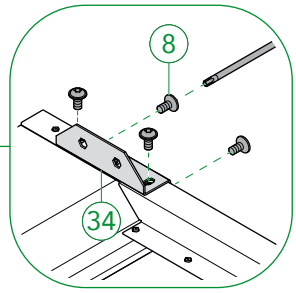
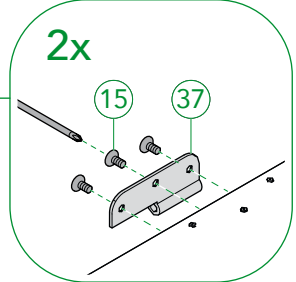
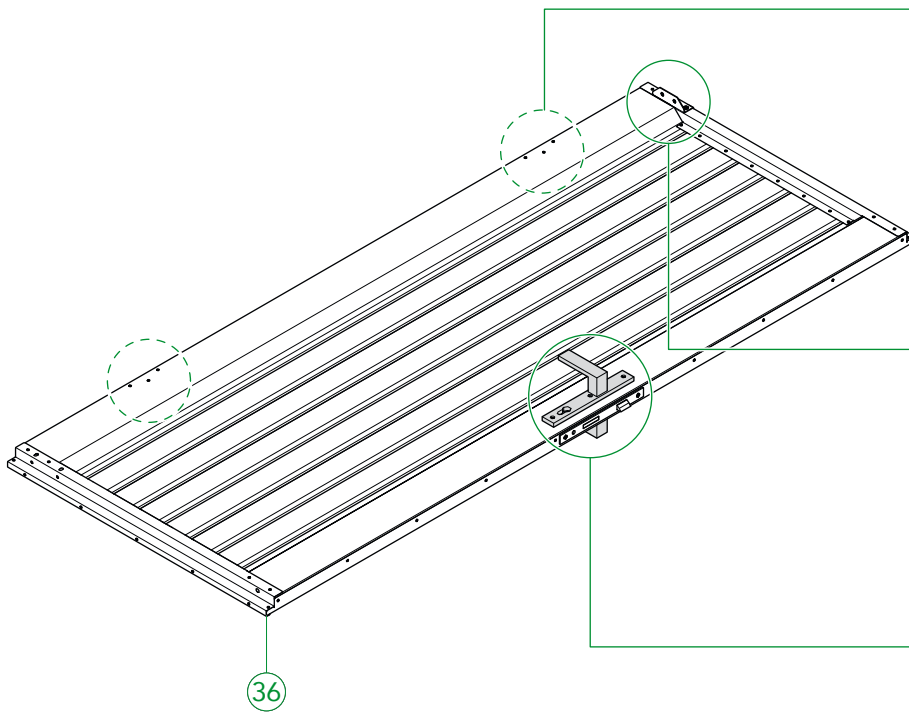

38

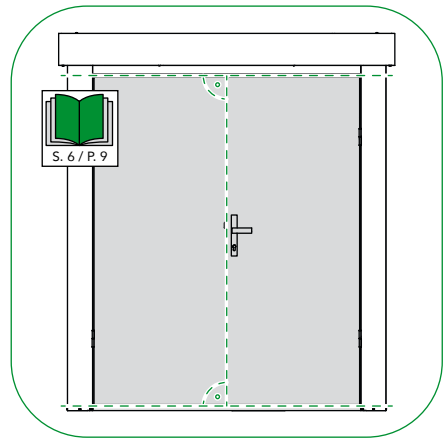
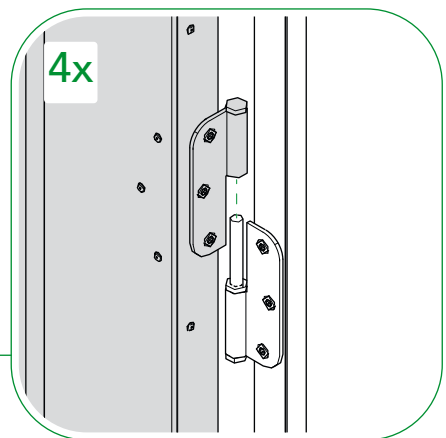
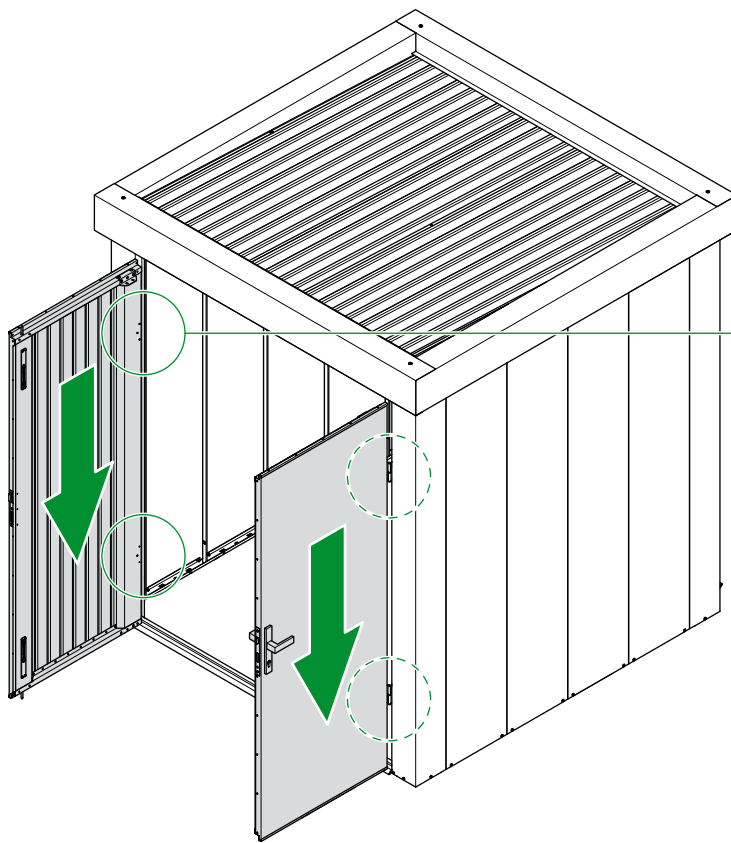

39 

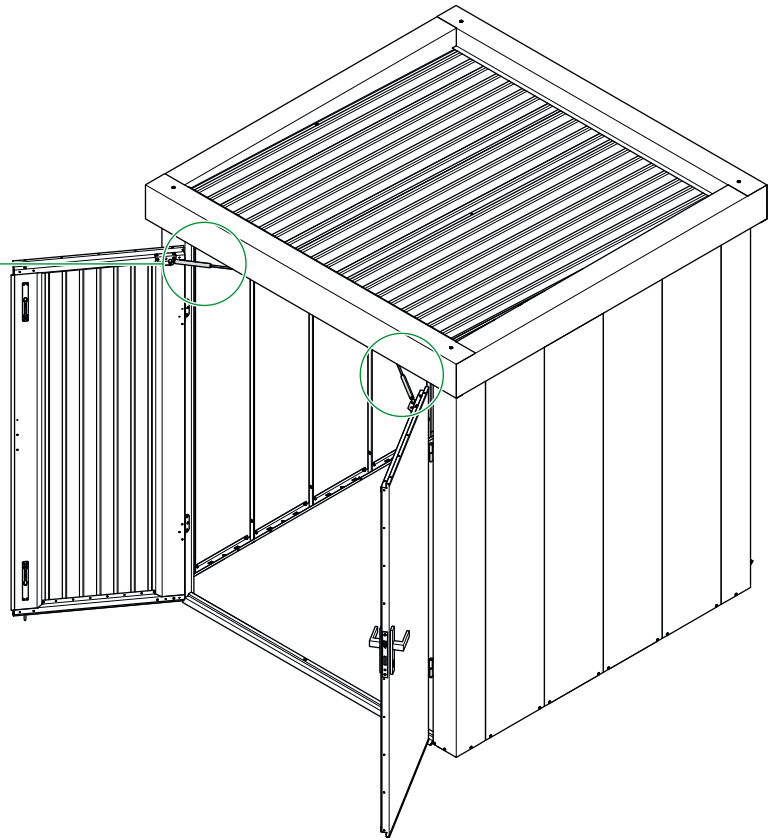
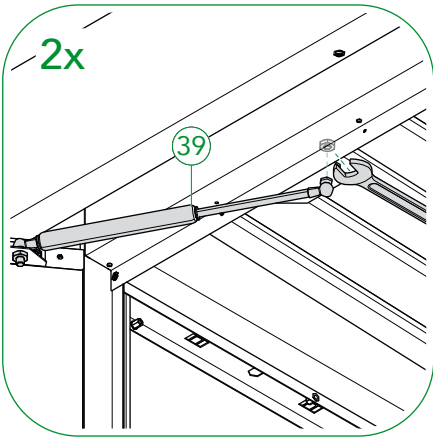

40

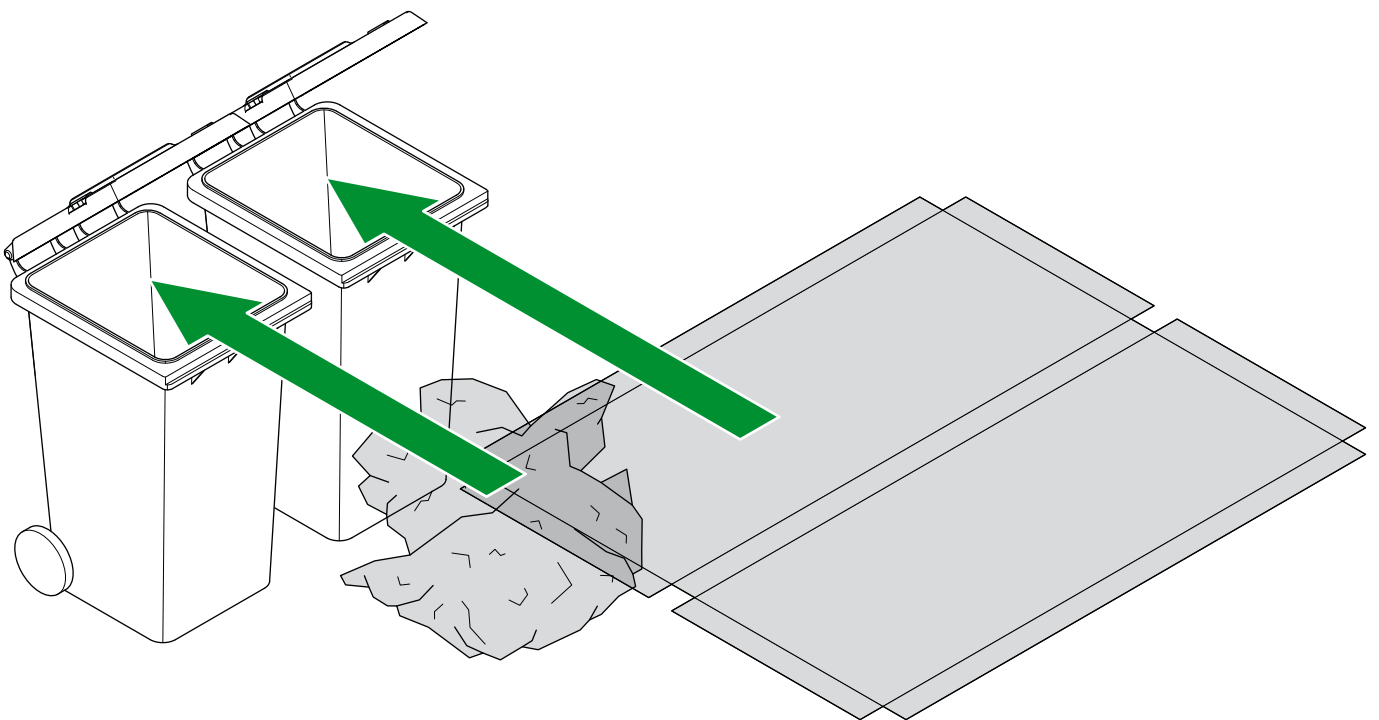

DE

Danke für Ihr Vertrauen!

Sie sind mit unserem Produkt zufrieden? Die ersten neidischen Blicke wurden gesammelt? Dann würden wir uns über eine Bewertung auf unserer Website, Facebook oder Instagram freuen!

www.guardi.at

www.facebook.com/GUARDIGmbH

www.instagram.com/guardi_gmbh

Wir sind stets bemüht, unsere Produkte und unseren Service für Sie zu verbessern.

Benötigen Sie weitere Hilfe oder Unterstützung beim Aufbau, helfen wir Ihnen gern. Bitte schreiben Sie uns ein E-Mail an shop@guardi.at oder kontaktieren Sie uns in Österreich unter +43 (0) 5 05 890 und in Deutschland unter +49 (0) 1807 000 777.

EN

Thank you for trusting us!

Happy with our product? Caught the neighbours sneaking an envious glance or two? We'd love you to leave a review on our website, Facebook or Instagram!

www.guardi.at

www.facebook.com/GUARDIGmbH

www.instagram.com/guardi_gmbh

We are constantly working to improve our products and service for you.

If you require further help or support with assembly, we will be happy to help. Please send us an email at shop@guardi.at